



Ross Valley Paramedic Authority

MEMBER AGENCIES

Town of Corte Madera
Town of Fairfax
Kentfield Fire Dist.
City of Larkspur
County of Marin
Town of Ross
Town of San Anselmo
Sleepy Hollow Fire Dist.

BOARD OF DIRECTORS MEETING

Thursday, August 2, 2018 @ 6:30 p.m. Kentfield Fire District
1004 Sir Francis Drake Blvd. Kentfield, CA 94904

1. Call to Order- Board Chair
2. Roll Call- Executive Officer
3. Pledge of Allegiance – Board Chair
4. Open Time for Public Input. Members of the Public have an opportunity to comment on items not on tonight's agenda. Each member of the public has two minutes in which to speak. Board members and staff are not able to engage in dialogue, answer questions or act on any of the items brought forward. At the Board's discretion, matters brought forth may be placed on a future agenda.
5. Review and approve Meeting Minutes: Staff recommends that the Board approve the meeting minutes from the March 1, 2018 meeting.
6. NEW BUSINESS
 - a. Authorize Executive Officer to execute purchase contract with Leader Industries utilizing a public competitive procurement process through HGAC in the amount of \$270,664.16 for the purchase of a 2019 Ambulance. *Recommendation: Authorize Executive Officer to enter into a purchase contract with Leader Industries.*
 - b. Update regarding ambulance billing transition, Medicare Payments and year end revenue projections. *Recommendation: Receive verbal report from Executive Officer, direct staff as needed.*
7. OLD BUSINESS
 - a. Update on November ballot measure for RVPA tax renewal, *Recommendation: Receive verbal report from Executive Officer.*
8. CQI Reports (Quarterly). Staff recommends that the Board receive any oral/written updates from the CQI managers. *Recommendation: Direct staff as needed.*
 - a. Marin County: Heather Price Fair
 - b. Town of Corte Madera: Liz Froneberger
9. Review RVPA Expense Sheet (attached).
10. Transport Billing Data Review (attached).
11. Announcements/Future Agenda Items.
12. Adjournment.

Submitted, /s/ Jason Weber, Executive Officer

This agenda was posted in accordance with #54954.2 and #54954.3 of the Government Code. AMERICAN SIGN LANGUAGE INTERPRETERS AND ASSISTIVE LISTENING DEVICES MAY BE REQUESTED BY CALLING (415)473-4100 AT LEAST 72 HOURS IN ADVANCE. COPIES OF DOCUMENTS ARE AVAILABLE IN ACCESSIBLE FORMATS UPON REQUEST.

Availability of Documents: Any writings or documents provided to a majority of the RVPA regarding any item on this agenda will be made available for public inspection at the Customer Service Counter at Marin County Fire Department Woodacre Station 33 Castlerock Ave, Woodacre 94973, during normal business hours.

THE BOARD OF DIRECTORS OF
THE ROSS VALLEY PARAMEDIC AUTHORITY
Held a Special Meeting:
6:30 p.m. Thursday, May 30, 2018
Kentfield Fire District
1004 Sir Francis Drake Blvd., Kentfield, CA. 94904

1. Call to Order by Chair Finn at 6:30 p.m.
2. Roll Call
Board Member Attendance: Chair Finn, Bailey (for Ravasio), Corbett, Hillmer, Przybylski, Reed Absent: Hart
Absent: Hart,
Staff: Weber, Meagor, Stasiaski, McTigue

3. Pledge of Allegiance
4. Open Time for Public Input

There were no comments.

5. Review and/or approve Meeting Minutes: From May 3, 2018

M/s, Reed/Hillmer, to approve the minutes of May 3, 2018 as submitted.
Ayes: All Absent: Hart Abstain: Przybylski

6. NEW BUSINESS
 - a. Adoption of FY 2018/19 Budget by Resolution

Executive Officer Weber presented a staff report.

Chair Finn thanked Executive Officer Weber for his work in stabilizing and fine-tuning the budget over the past couple of years. Executive Officer Weber referred to the ALS Back-up line item, in the amount of \$100,000, and stated it was reduced to \$62,500. The rest of the budget remains unchanged. There is an anticipated Fund Balance at the end of the year of around \$112,000. The current Fund Balance is \$793,000- \$100,000 is earmarked for the Equipment Replacement Fund and the rest is undesignated. It could be transferred to the Equipment Reserve Fund for purchase of an ambulance. The cost of a new ambulance would be anywhere from \$215,000 to \$260,000 depending on the type of chassis. This decision would be brought back to the Board in July.

Chair Finn mentioned the beneficial effect of capping the County Contract at a 3% increase. The Engine Medic Programs for Larkspur and Ross Valley were big ticket items- Larkspur budgets for seven paramedics and Ross Valley budgets for 10 paramedics. He referred to the ALS Back-up line item and stated

the City of Larkspur and the Town of Corte Madera continue their merger negotiations. Executive Officer Weber stated the Board could continue to discuss how to handle the Engine Medic Programs.

There were no comments from the public.

M/s, Hillmer/Przybylski, to adopt the resolution approving the Fiscal Year 2018-19 Budget as proposed by staff.

Ayes: All Absent: Hart

b. Adoption of ambulance service fees by resolution

Executive Officer Weber presented a staff report. He noted staff was recommending that the RVPA more closely align with similar agencies in the region. Medicare and Medical local rates are based on a regional level. Staff is also recommending a change in some of the fee structures- the costs for an ALS and BLS transport are the same. He is asking the Board to strike the ALS 2 fee. There is a slight change in the mileage.

Chair Finn noted the RVPA base rate was \$200 below the average rate and it makes sense to get caught up.

Boardmember Reed supported the recommended change in the ALS/BLS rate since it would reflect actual costs.

There were no comments from the public.

M/s, Hillmer/Reed, to adopt the resolution approving the ambulance service fees as proposed by staff.

Ayes: All Absent: Hart

c. Tax Renewal proposal for consideration by JPA member agencies

Executive Officer Weber presented a staff report. Staff is recommending an increase of \$4.00. Chair Finn stated the Finance Committee agreed that an increase of \$4.00 was sufficient for their needs. However, the fee does not have to go up by \$4.00 each year.

Boardmember Bailey thanked Executive Officer Weber and Chief Shurtz for their explanation of the spread sheet and the process.

Chair Finn stated each jurisdiction must take action in a timely manner to get this measure on the ballot.

Executive Officer Weber stated there was a question pertaining to the ballot argument- should the \$.50 administrative fee be included so it is charged to the parcel owner or should it be borne by individual agencies. County counsel is of the opinion that it is the responsibility of the parcel owner.

Chief Meagor had a comment about the fourth paragraph on the third page of the ballot argument.

Chair Finn reminded everyone to have the ballot arguments and reply arguments, if there are any, in hand and ready to go before the filing deadline.

Executive Officer Weber referred to page 4 of the staff report, the third bullet point, and asked about the following language: “..maintain rapid emergency response times...”. Chief Meagor suggested the following: “..maintain rapid emergency medical response...”. The Board agreed with this language.

There were no comments from the public.

M/s, Reed/Przybylski, to adopt the Resolution subject to the County counsel’s input on the administrative charge.

Ayes: All Absent: Hart

7. OLD BUSINESS

a. Ambulance Billing Provider

Executive Officer Weber presented a staff report. He noted there was a benefit to using the services of Wittman Enterprises LLC since other agencies have also signed on with them. The proposal is 3.99% of net receivables, which equals about \$32,000. The prior arrangement with Wittman Enterprises was 5.65%. Staff also looked at whether it was better to bill per ticket or use a percentage. Staff decided on the latter. Executive Officer Weber stated staff was familiar with this company and Wittman Enterprises already has all the RVPA data and was familiar with the systems. He noted staff has received other quotes that were considerably higher.

Chair Finn asked if there was a deadline for completing the agreement. Executive Officer Weber stated staff would like to make the change by July 1st.

Chair Finn asked if there might be a problem getting the data from the former provider (Novato Fire) to Wittman Enterprises. Battalion Chief McTigue stated Wittman has the accounts ready to go- personnel lists, vehicle numbers, etc.

Boardmember Przybylski asked how long they were with the former provider. Executive Officer Weber stated since August 1, 2017.

There were no comments from the public.

M/s, Bailey/Finn, to authorize Executive Officer Weber to execute the agreement with Wittman Enterprises LLC as the ambulance billing provider and to allow him to make necessary changes to the language.

Ayes: All Absent: Hart

8. CQI Presentation
 - a. Receive update from CQI staff including American Heart Association Silver Award

Executive Officer Weber stated this item would be continued to the July Board meeting.

9. Announcements

Executive Officer Weber noted the regularly scheduled June Board meeting would not be necessary. The next meeting would be held on July 5th.

10. Adjournment- Chair Finn adjourned the meeting at 7:15 p.m.

Respectfully submitted,

Toni DeFrancis
Recording Secretary

RVPA Staff Report

TO: RVPA Board
FROM: Jason Weber, Executive Officer
SUBJECT: Replacement Paramedic Ambulance
MEETING DATE: August 2, 2018

BACKGROUND

The current ambulance being used as the primary transport unit for RVPA has reached the end of its useful life. The current unit was remounted on a new chassis approximately 5 years ago. The box has been in service for nearly 10 years and served the JPA well.

DISCUSSION

We have reviewed options for purchasing a new ambulance including light to medium duty chassis vs commercial chassis. The assessment compares projected repair costs, original purchase costs and consideration of re-mounting the box on a new chassis in approximately five years.

STAFF RECOMMENDATION

Staff is recommending the purchase of a new ambulance on a 2019 Freightliner with a comfort ride system, passenger safety features including airbags. The total purchase cost is \$270,664.16 utilizing a public competitive procurement process through Houston Galveston Area Cooperative (HGAC). We will utilize the existing gurney and gurney lift system that will be re-installed in the new unit (Approx. \$50K value). Detailed information including the quote are attached for your reference. RVPA has a sufficient cash position to make this purchase without financing.



CONTRACT PRICING WORKSHEET
For MOTOR VEHICLES Only

Contract No.:

AM10-16

Date Prepared:

7/10/2018

*This Form must be prepared by Contractor, and provided to End User to attach to Purchase Order, with copy to H-GAC.
The H-GAC administrative fee shall be calculated and shown as a separate line item. Please type or print legibly.*

Buying Agency:	Ross Valley Paramedic Authority		HORTON EMERGENCY VEHICLES
Contact Person:	BRET MCTIGUE	Prepared By:	NATALIE CARROLL
Phone:	415-473-6095	Phone:	866-356-2236
Fax:		Fax:	325-356-3360
Email:		Email:	natalie.carroll@proambulance.net

Product Code:	KA10	Description:	HORTON TYPE I FREIGHTLINER M2
---------------	------	--------------	-------------------------------

A. Product Item Base Unit Price Per Contractor's H-GAC Contract: 201,285

B. Published Options - Itemize below - Attach additional sheet(s) if necessary - Include Option Code in description if applicable.
(Note: Published Options are options which were submitted and priced in Contractor's bid.)

Description	Cost	Description	Cost
SEE ATTACHED PAGE			
		Subtotal From Additional Sheet(s):	
		Subtotal B:	56,456

C. Unpublished Options - Itemize below / attach additional sheet(s) if necessary.
(Note: Unpublished options are items which were not submitted and priced in Contractor's bid.)

Description	Cost	Description	Cost
CUSTOM PAINT & LETTERING	11,923		
		Subtotal From Additional Sheet(s):	
		Subtotal C:	11,923

Check: Total cost of Unpublished Options (C) cannot exceed 25% of the total of the Base Unit Price plus Published Options (A+B). **For this transaction the percentage is:** 5%

D. Other Cost Items Not Itemized Above (e.g. Installation, Freight, Delivery, Etc.)

Description	Cost	Description	Cost
		Subtotal D:	0

E. Total Cost Before Any Applicable Trade-In / Other Allowances / Discounts (A+B+C+D)

Quantity Ordered:	1	X Subtotal of A + B + C + D:	269,664	=	Subtotal E:	269,664
-------------------	---	------------------------------	---------	---	-------------	---------

F. H-GAC Fee Calculation (From Current Fee Tables) **Subtotal F:** 1,000

G. Trade-Ins / Other Allowances / Special Discounts

Description	Cost	Description	Cost
		Subtotal G:	

Delivery Date: **H. Total Purchase Price (E+F+G):** 270,664

MARIN COUNTY FIRE DEPT

PUBLISHED OPTIONS

Code or Part No.	Option Description	Offered Price
BA300000	WALK THROUGH CHASSIS MODIFICATION FOR FREIGHTLINER CHASSIS	2895
BH03B000	MUD FLAPS: REAR	134
BH10B000	REAR TOW HOOKS	180
BH120000	REAR STEP/ BUMPER ASSEMBLY	1315
BL07A000	PULL OUT TRAY FOR 3-BATTERY SYSTEM	214
BH08DD00	RUNNING BOARDS, DIAMOND PLATE W/ UNDERCAB CLOSEOUT	986
CB06SW10	STREETSIDE OF BODY LOWERED 3" FROM STANDARD	805
CB06SX00	DOUBLE STEP CURBSIDE ENTRY 6" DROP SKIRT	805
DG05C100	PRIVACY WINDOWS, REAR MODULE BODY ENTRY DOORS	184
DG06C200	PRIVACY WINDOW, SLIDING FOR SIDE ENTRY DOOR	135
DG07R000	EMERGENCY DOOR RELEASE MECHANISM, SIDE DOOR	193
DH330000	REAR DOOR HOLD OPENS, GRABBER	122
DLH40000	RECESSED LICENSE PLATE BRACKET	202
DM100000	REFLECTORS: (20)	1120
DR12A000	ROK BACKBOARD STRAP	36
CB040W00	COMPARTMENT WIDTH MODIFY: FIRST, STREET SIDE	1125
CB040000	COMPARTMENT HEIGHT MODIFY: FIRST, STREET SIDE	966
CB03SO00	SWEEP OUT COMPARTMENT FLOOR MODIFICATION (2)	404
CBR12A00	STREET SIDE WHEEL WELL COMPARTMENT W/HINGED DOOR & PULL OUT TRAY	1125
CB04A000	COMPARTMENT HEIGHT MODIFY: SECOND, STREET SIDE	565
CB04AW00	COMPARTMENT WIDTH MODIFY: SECOND, STREET SIDE	724
DR10D000	TOOL MOUNTING PLATE	249
DH100000	STAINLESS COMPARTMENT SILL PLATES: (3)	243
DR08ALF0	FIXED SHELF FOR LED LIGHTED SINGLE DOOR EXTERIOR COMPARTMENT	217
DR11CL00	CLOSEOUT, EXTERIOR COMPARTMENT	125
DR11A000	DIVIDER FIXED, VERTICAL COMPARTMENT	298
DR11S000	BACKBOARD RETENTION CHANNELS	135
DR11B000	DIVIDER ADJUSTABLE, VERTICAL COMPARTMENT	404
DR11P000	STAIR CHAIR POCKET, RECESSED	197
DR11CL00	CLOSEOUT, EXTERIOR COMPARTMENT	125
BL07A000	PULL OUT TRAY FOR 3-BATTERY SYSTEM	214
DR220000	RUBBER MATTING IN EXTERIOR COMPARTMENTS	81

DR23A000	RUBBER COVERED WALLS IN BACKBOARD COMPARTMENT	283
DR23GL00	GRIP LOCK TRIM ON FACE OF EXTERIOR SHELVES AND DIVIDERS	144
FE07A000	STAINLESS STEEL-INHALATION AREA WALLS:	453
FE08A000	STAINLESS STEEL-INHALATION PANEL:	532
FE08SV00	INHALATION PANEL CLOSEOUT	165
GF030000	STAINLESS STEEL RISER, CABINET WALL	243
GF03C000	STAINLESS STEEL LOWER DOOR PANELS	361
GK150000	SEAT BELTS: 4-POINT HARNESS (3)	1737
KG02A000	I.V. HOOKS: PERKO	48
KG02C000	IV HANGER, CAST PRODUCTS WITH RUBBER ARM	122
KG07A000	CEILING GRAB RAIL: (2) 2FT RAILS OR (1) 6FT RAIL	128
KG07E000	GRAB RAIL: 8FT	161
KG07J000	PATIENT DOOR GRAB RAILS: ANGLED	393
KG16C000	CEILING MATERIAL, PLATINUM WHITE ALUMINUM COMPOSITE	1065
KG17A000	FIRE EXTINGUISHERS: 5LB ABC	90
HK000000	LINEN CLOSET	1207
FE02E000	REPLACE SLIDING PLEXIGLAS DOORS (PER PAIR) (2)	282
HK01R000	LIFT UP CABINET FRAMES: (2)	566
HK160000	EXTRA SHELF: INTERIOR (2)	244
HK16A000	DIVIDER: INTERIOR (13)	858
HK02LU00	STORAGE BENEATH THE CPR SEAT	243
IK29C000	GLOVE STORAGE CABINET	565
IG07A110	FULL HEIGHT SQUAD BENCH END RESTRAINT FOR USE WITH HOPS	1065
IG10A000	BENCH HOLD OPENS: GAS	137
IG10Q000	BENCH HOLD-DOWN: PADDLE LATCHES (PAIR)	277
IG15A000	BENCH CUSHION EDGE TRIM:	115
IG15B000	BENCH BACK CUSHION: FULL SIZE	243
IK040000	SLIDING DRAWER:	483
HK11A000	DRUG BOX: ENCLOSED	243
JE05R210	ROBINSON ROLL UP DOOR, HALF HEIGHT	1046
JAK03G00	GLOVE STORAGE ABOVE FRONT WALL CABINET	511
LG03B500	COT SAFETY HOOK	83
MAM20B00	LIGHT BAR MOUNT: FRONT FACE OF BODY	210
MBM20C00	LIGHT BAR MOUNT: REAR FACE OF BODY	210
MM01A000	WIG WAG HEADLIGHTS:	184

MM09A000	M9 SERIES LED, AMBER (2)	924
MM07A000	M7 SERIES LED, AMBER	335
MM09R000	M9 SERIES LED, RED (6)	2772
MM04R000	M4 SERIES LED, RED (4)	3154
MN35CC00	SIREN: WHELEN 295SLSC1 W/ 295 COPT	583
MN45FL00	SPEAKERS: C.P. FREIGHTLINER	798
OL09M000	KKK SIDE BODY MARKER LIGHTS, M6 SERIES L.E.D. (PAIR)	658
OL33P000	FOG LIGHTS, PIAA ION CRYSTAL #2091	420
OM25CW0	M9 SERIES LED SCENE LIGHT (4)	2936
OM30D000	TAIL LIGHTS, M6 SERIES	1668
DL480000	ELECTRIC DOOR LOCKS: COMPARTMENT	866
DL48A000	ELECTRIC DOOR LOCKS: ACCESS DOORS	243
DL48D000	ELECTRIC DOOR LOCKS WIRED TO OEM SWITCHES	161
DL48B000	ELECTRIC DOOR SWITCH: CONCEALED	122
HK12S000	IV WARMER, SMITHWORKS	571
OL35F000	360 DEGREE MARKER LIGHTS, EMERGENCY FLASH	122
PAL30AR0	110V INTERIOR OUTLET (2)	356
PAL31CR0	INTERIOR 12VDC OUTLETS: CIGARETTE LIGHTER TYPE (4)	540
PAL38C00	SHORELINE: 20 AMP EJECT	596
PAL39000	WIRE ENGINE BLOCK HEATER:	243
PAL40000	EXTRA 12VDC CIRCUIT BREAKER:	34
PL19A000	REPORT LIGHT: LED	178
PL23A000	2.5" CAB CEILING LIGHTS, COMBINATION WHITE/RED LED	220
PAL00T20	THREE SWITCH PANEL, I4G	290
PL24T000	LAMP TIMER: PROGRAMMABLE (2)	580
PL29D000	FLASHLIGHT, STREAMLIGHT SL20 WITH CHARGER (2)	518
PL29R000	SPOTLIGHT, CAB ROOF MOUNTED	618
PM110000	LIGHT PROGRAMMING: BRAKE LIGHT	122
QH300000	ULTRAVIOLET LAMP IN A/C SYSTEM DUCT	391
QL43N000	NFPA COMPLIANT VENTING-CAST VENTS	346
TN01B200	DUAL O2 BOTTLE SYSTEM, 1-REGULATOR WITH CHECK VALVES	636
TN01B300	OXYGEN BOTTLE TRANSFILL SYSTEM W/3' STAINLESS HOSE	404
TN020000	OXYGEN ACCESS:	148
TN01B200	DUAL O2 BOTTLE SYSTEM, 1-REGULATOR WITH CHECK VALVES	636
TN01B300	OXYGEN BOTTLE TRANSFILL SYSTEM W/3' STAINLESS HOSE	404

TN020000	OXYGEN ACCESS:	148
TN03A000	OXYGEN OUTLET: ADDITIONAL (3)	870
TN060000	OXYGEN WRENCH:	56
TN11B000	ASPIRATOR: SSCOR	277
TN12B000	VACUUM PUMP: CAPL #D34 SE (T282)	292
TOTAL		\$56,456

LEADER INDUSTRIES

Steve De La Montanya
10941 Weaver Avenue
So El Monte, CA 91733
707-529-7522

Ross Valley Paramedic Authority

33 Castle Rock Ave
Woodacre, CA 94973
Bret McTigue

(415) 473-6095



Parent Job 2352

THE ABOVE ITEMS ARE ALREADY INCLUDED IN THE CONTRACT PRICE .

SHIPPING FOB Marin County D.P.W. Shops: San Rafael CA.

	<i>Each</i>	<i>Extended Amount</i>
1 Subtotal for base vehicle, rebates and discounts :	\$243,699.00	\$243,699.00
Subtotal for all option items:	0.00	0.00
SUB TOTAL FOR VEHICLE AND ALL ITEMS IN THE CONTRACT :	243,699.00	243,699.00
Leader Municipal Customer Discount:	(2,000.00)	(2,000.00)

Subtotal for base vehicle and all taxable items:	\$241,699.00	\$241,699.00
Sales tax calculated at : 9.00 %	21,752.91	21,752.91
H-GAC fees:	1,000.00	1,000.00
7 Tires fees (\$1.75) per tire:	12.25	12.25
Delivery Fees:	3,400.00	3,400.00

Two person final inspection @ Horton Facility, Grove City Ohio: 2,800.00

Contract Total: \$270,664.16 \$270,664.16

Estimated delivery is 240 days from order confirmation (subject to chassis availability)

Customer Representative Date: _____

Payment: (Please check one)

Leasing

Company Check

Wire Transfer

Purchaser agrees to defend, indemnify and hold Halcore Group Inc., dba Leader Industries, harmless from any claims, costs (including actual attorney's fees), damages and liabilities caused in whole or in part by any alteration or modification of, or changes or additions to these purchased products.

TERMS: All Vehicle Sales Are C.O.D. Titles to be Processed Upon Receipt of Payment in Full.

Quotation is valid for 60 days

THANK YOU FOR YOUR BUSINESS

MARIN COUNTY

603C WT EXTERIOR FREIGHTLINER CHASSIS

COMP'T	INSIDE WIDTH	INSIDE HEIGHT	INSIDE DEPTH	CLEAR OPENING WIDTH	CLEAR OPENING HEIGHT
CS REAR	22.25	81.63	21.96	17.73	80.66
CS INT	29.50	21.46	21.96	24.63	18.46
CS FWD				16.13	86.66

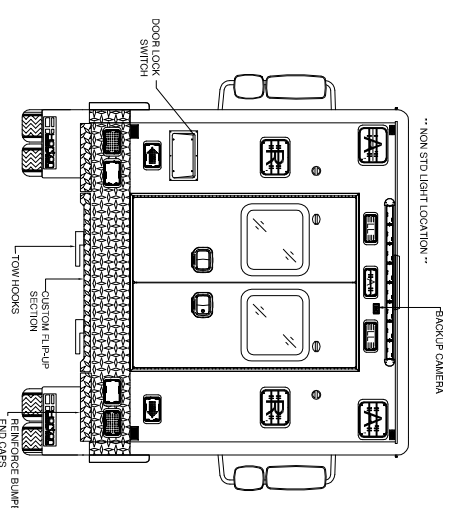
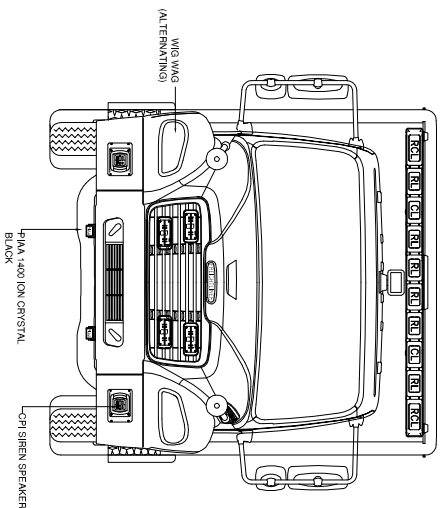
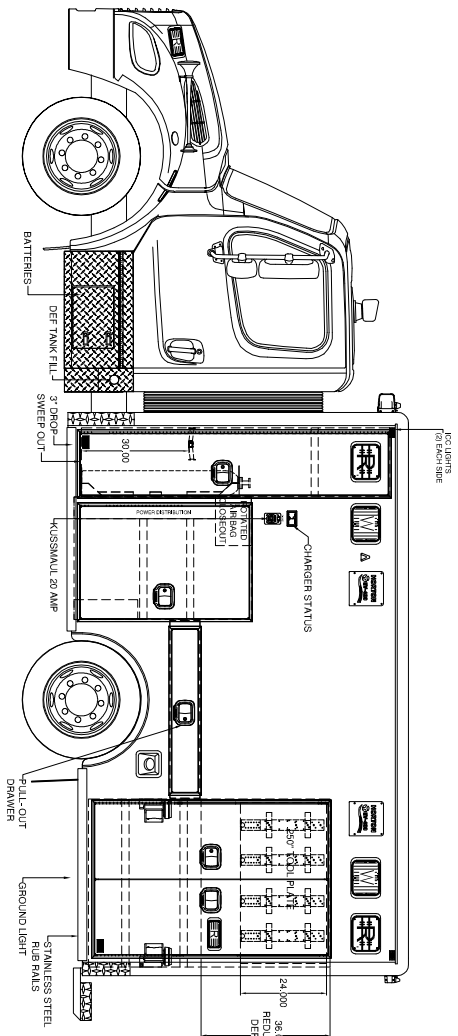
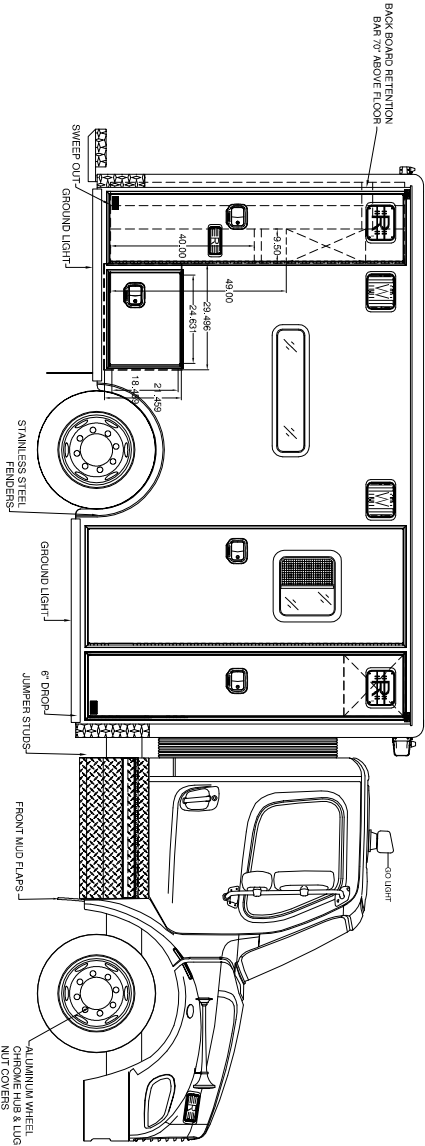

COMP -	INSIDE WIDTH	INSIDE HEIGHT	INSIDE DEPTH	CLEAR OPENING WIDTH	CLEAR OPENING HEIGHT
SS FWD	18.95	66.83	21.96	16.23	84.86
SS INT	33.91	49.00	21.96	30.28	45.87
SS LOW	49.29	8.25	21.96	45.45	6.26
SS REAR	46.64	67.00	21.96	41.29	63.87

NOTE: DRAWINGS ARE FOR GRAPHICAL REPRESENTATION ONLY. DIMENSIONS ARE APPROXIMATE & MAY VARY DURING CONSTRUCTION.

PROPOSAL DRAWING

17712-112

REV	DESCRIPTION	DATE
A	603C EXTERIOR	12/21/17

DRAWN BY: RSA

MARIN COUNTY

603C WT EXTERIOR FREIGHTLINER CHASSIS

REVISIONS		DATE
REV	DESCRIPTION	
A	603 EXTERIOR	12/21/17

DRAWN BY: RSA

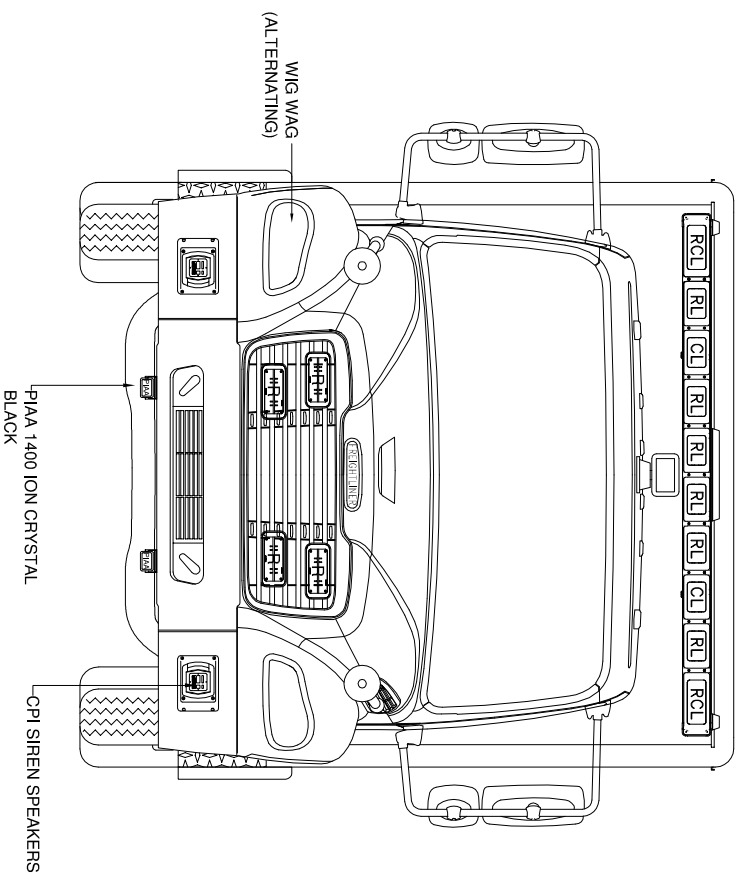
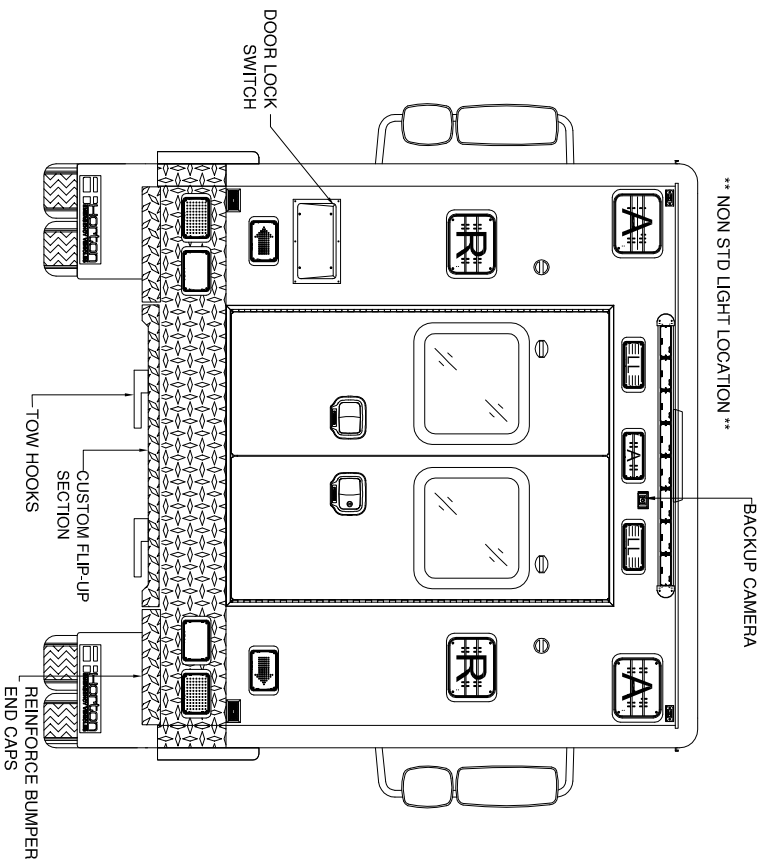

NOTE: DRAWINGS ARE FOR GRAPHICAL REPRESENTATION ONLY. DIMENSIONS ARE APPROXIMATE & MAY VARY DURING CONSTRUCTION

PROPOSAL DRAWING

17712-112

MARIN COUNTY

603C WT EXTERIOR FREIGHTLINER CHASSIS

REVISIONS		
REV	DESCRIPTION	DATE
A	603 EXTERIOR	12/21/17

DRAWN BY: RSA

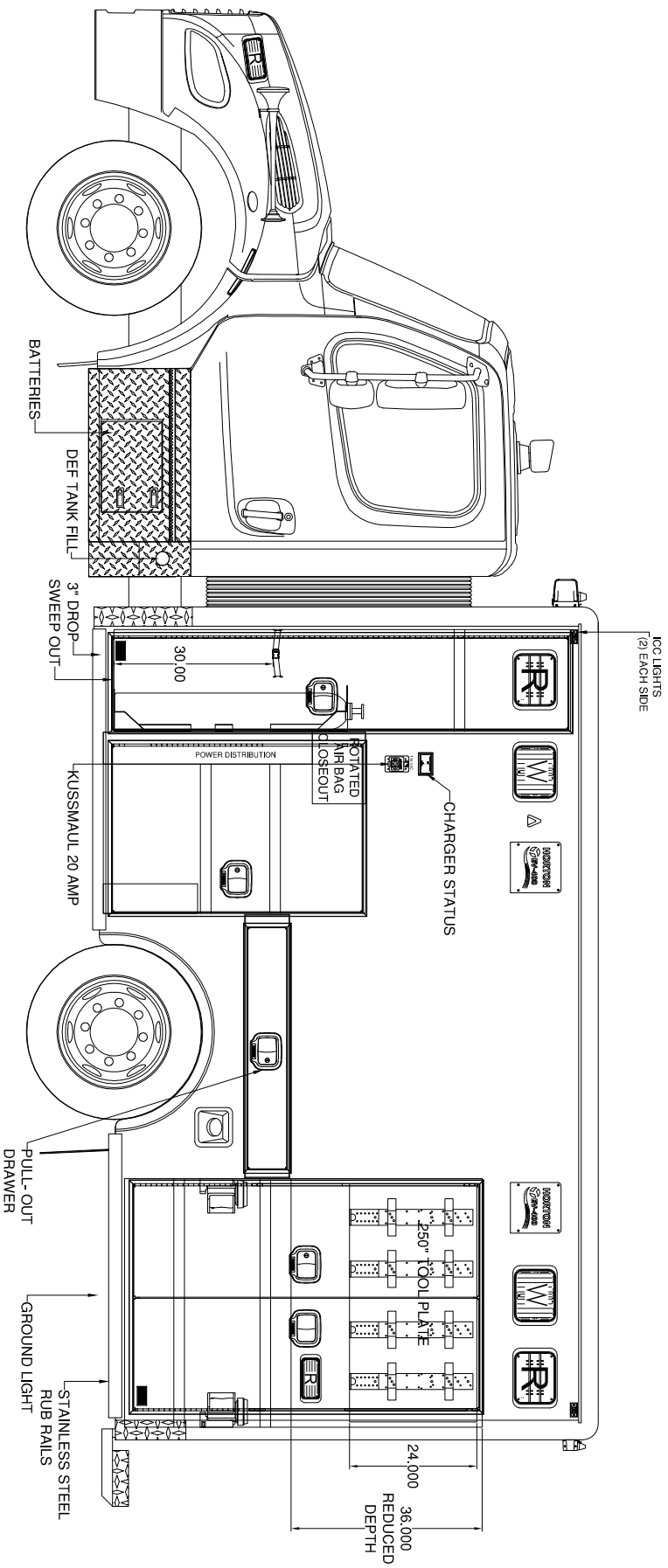

COMP.	INSIDE WIDTH	INSIDE HEIGHT	INSIDE DEPTH	CLEAR OPENING WIDTH	CLEAR OPENING HEIGHT
SS FWD	18.95	85.63	21.96	16.25	84.66
SS INT	33.91	49.00	21.96	30.28	45.87
SS LOW	49.39	8.25	21.96	45.45	6.36
SS REAR	46.64	67.00	21.96	41.29	63.87

NOTE: DRAWINGS ARE FOR GRAPHICAL REPRESENTATION ONLY. DIMENSIONS ARE APPROXIMATE & MAY VARY DURING CONSTRUCTION

PROPOSAL DRAWING

17712-112

MARIN COUNTY

603C WT EXTERIOR FREIGHTLINER CHASSIS

REVISIONS		DATE
REV	DESCRIPTION	
A	603 EXTERIOR	12/21/17
DRAWN BY: RSA		

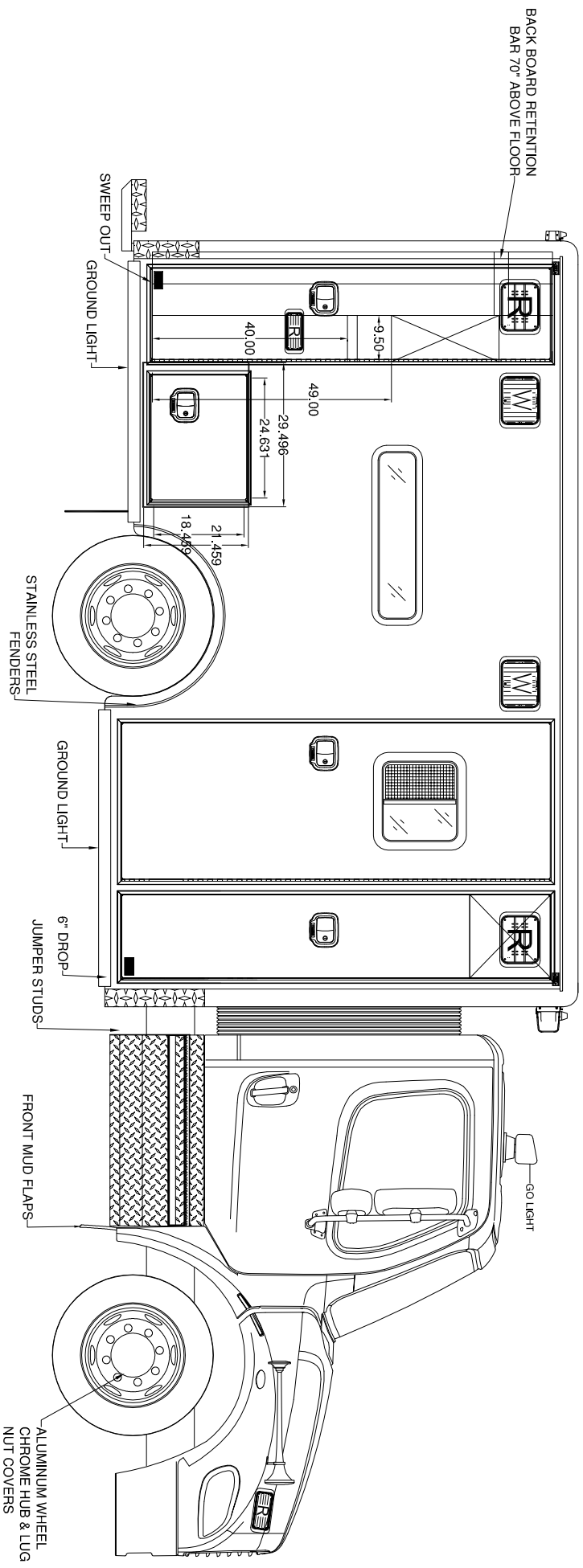

COMP	INSIDE WIDTH	INSIDE HEIGHT	INSIDE DEPTH	CLEAR OPENING WIDTH	CLEAR OPENING HEIGHT
CS REAR	22.25	81.63	21.96	17.73	80.66
CS INT	29.50	21.46	21.96	24.63	18.46
CS FWD				16.13	98.66

NOTE: DRAWINGS ARE FOR GRAPHICAL REPRESENTATION ONLY. DIMENSIONS ARE APPROXIMATE & MAY VARY DURING CONSTRUCTION

PROPOSAL DRAWING

17712-112

MARIN COUNTY

603C WT CABINET WALL "B" FREIGHTLINER CHASSIS

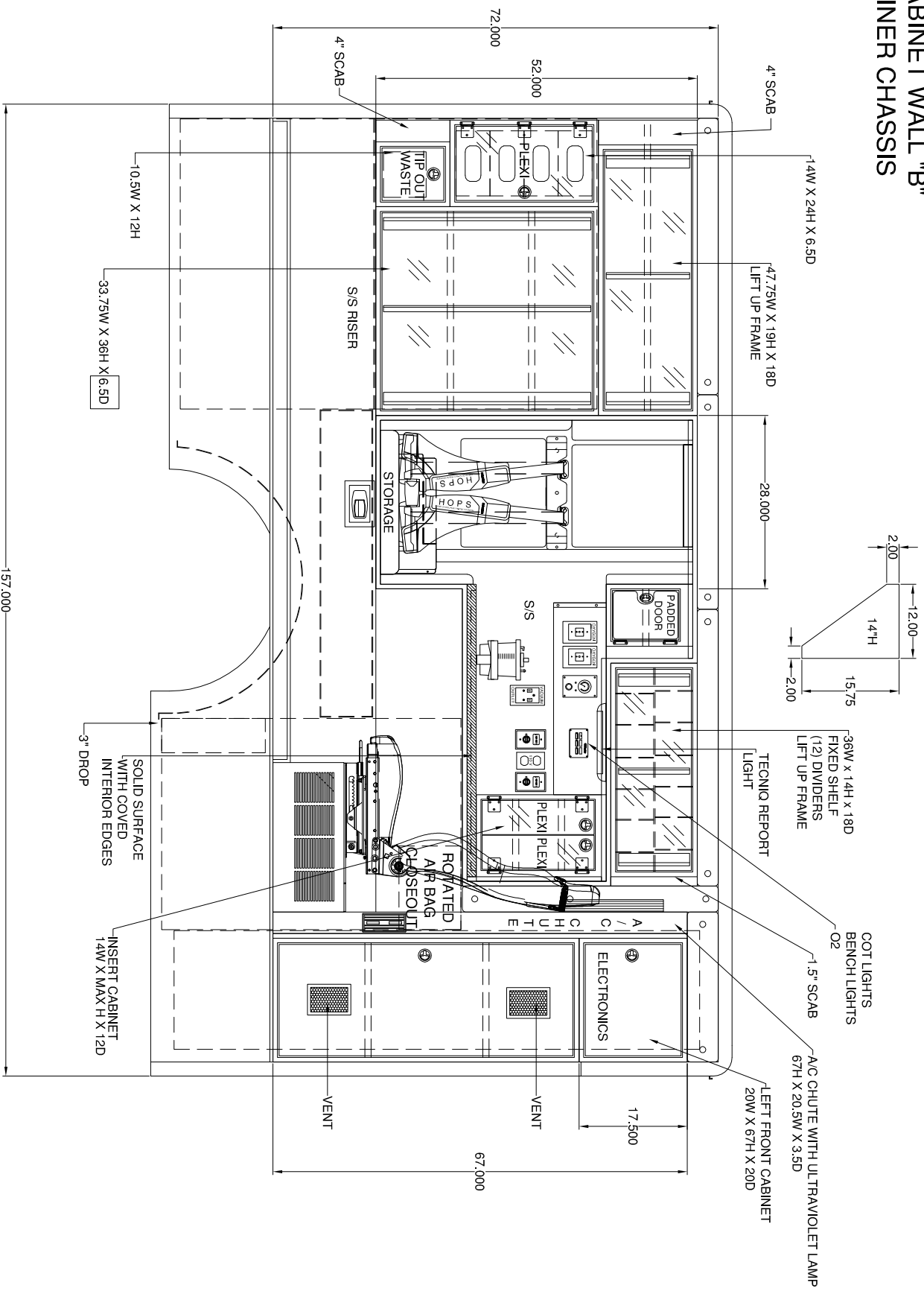

REVISIONS		
REV	DESCRIPTION	DATE
A	603 CABINET WALL B	12/21/17

DRAWN BY: RSA

PROPOSAL DRAWING

17712-112

MARIN COUNTY

603C WT FRONT WALL FREIGHTLINER CHASSIS

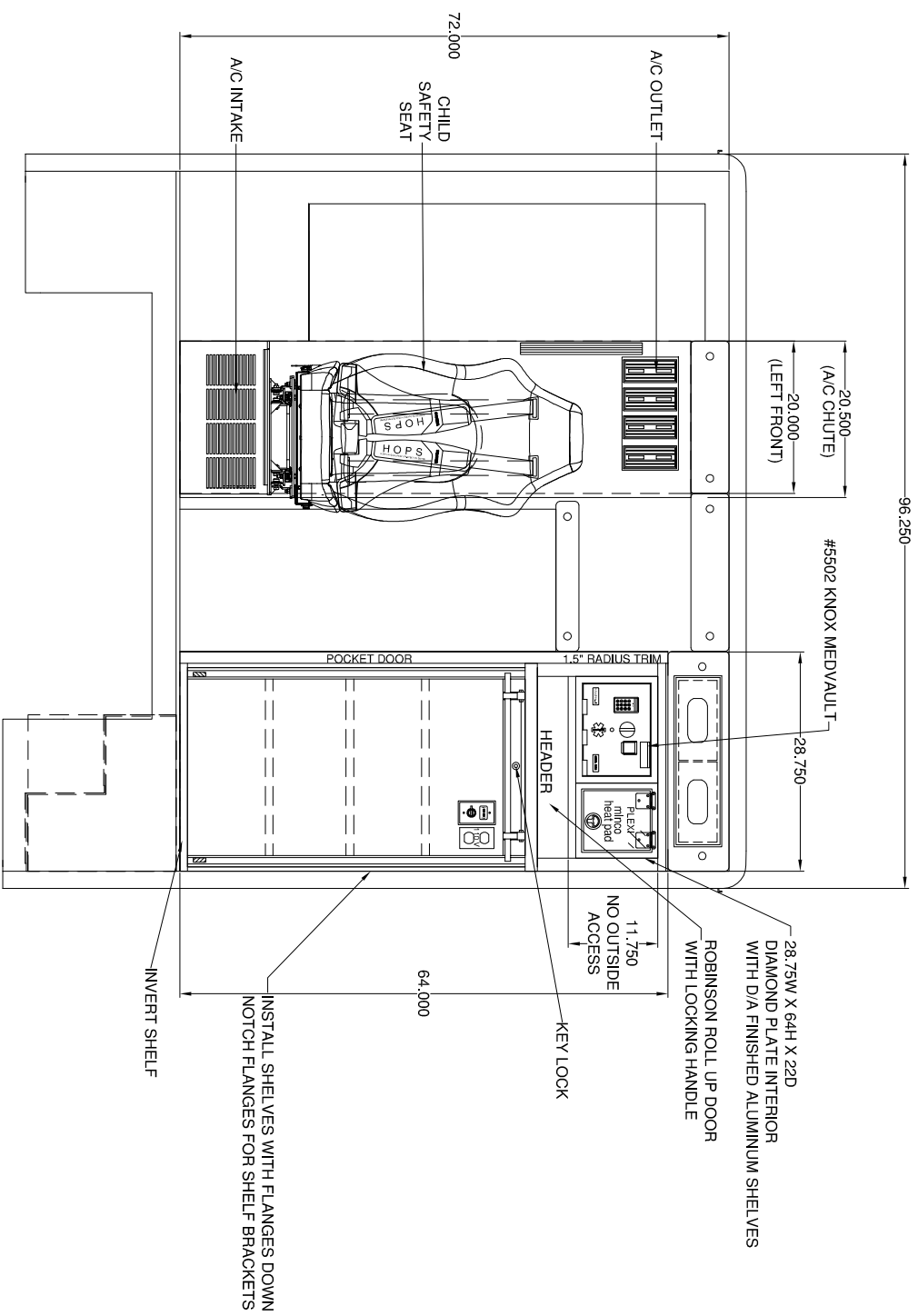

NOTE: DRAWINGS ARE FOR GRAPHICAL REPRESENTATION ONLY. DIMENSIONS ARE APPROXIMATE & MAY VARY DURING CONSTRUCTION.

PROPOSAL DRAWING

1712-112

REVISIONS		
REV	DESCRIPTION	DATE
A	603C FRONT WALL	12/21/17
DRAWN BY: RSA		

MARIN COUNTY FIRE

603C WT SIDE WALL FREIGHTLINER CHASSIS

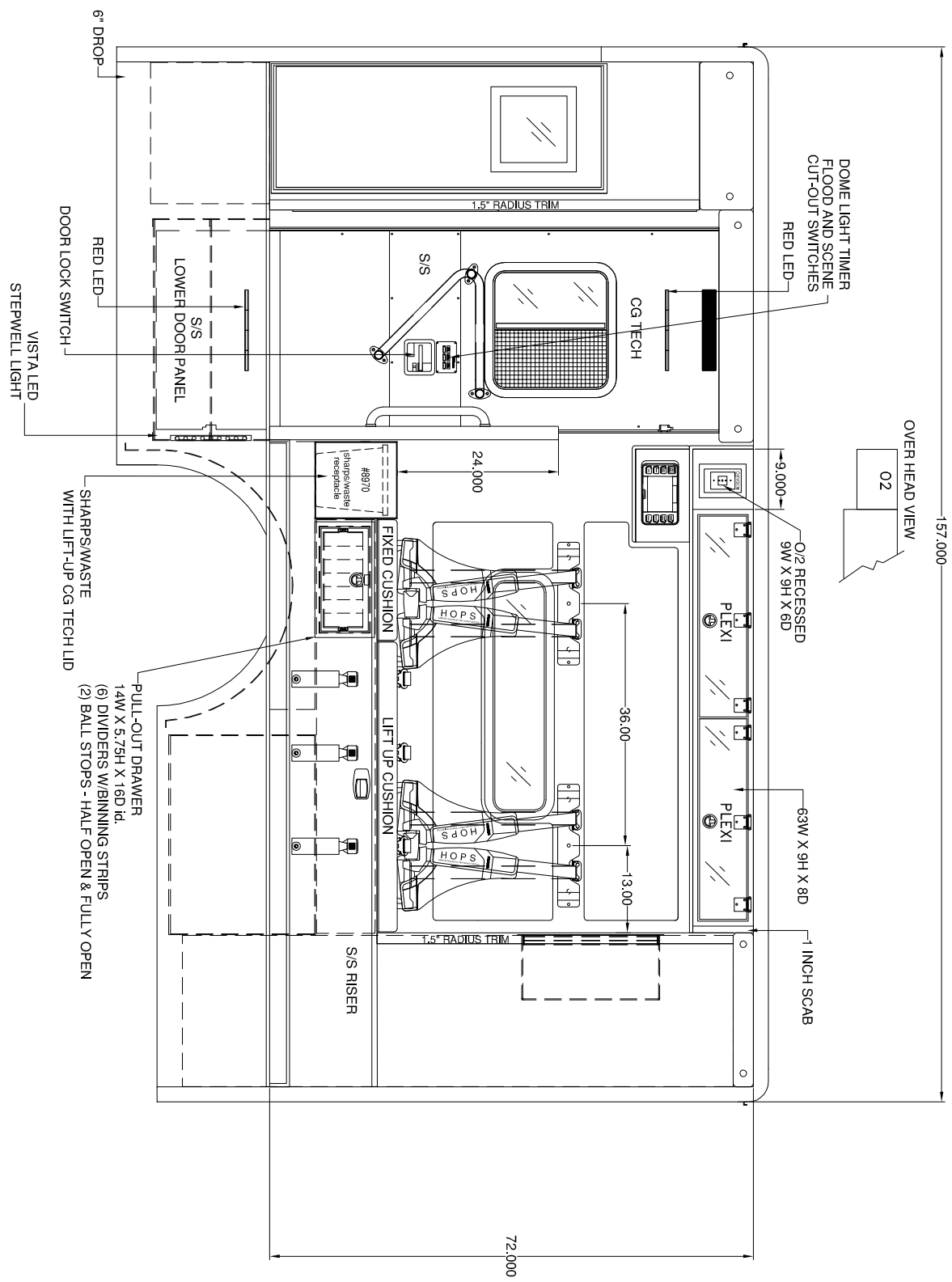

PROPOSAL DRAWING

1712-112

REVISIONS		
REV	DESCRIPTION	DATE
A	603C SIDE WALL	12/21/17
DRAWN BY: RSA		

MARIN COUNTY

603C WT REAR WALL FREIGHTLINER CHASSIS

REVISIONS		
REV	DESCRIPTION	DATE
A	603C REAR WALL	12/21/17
DRAWN BY: RSA		

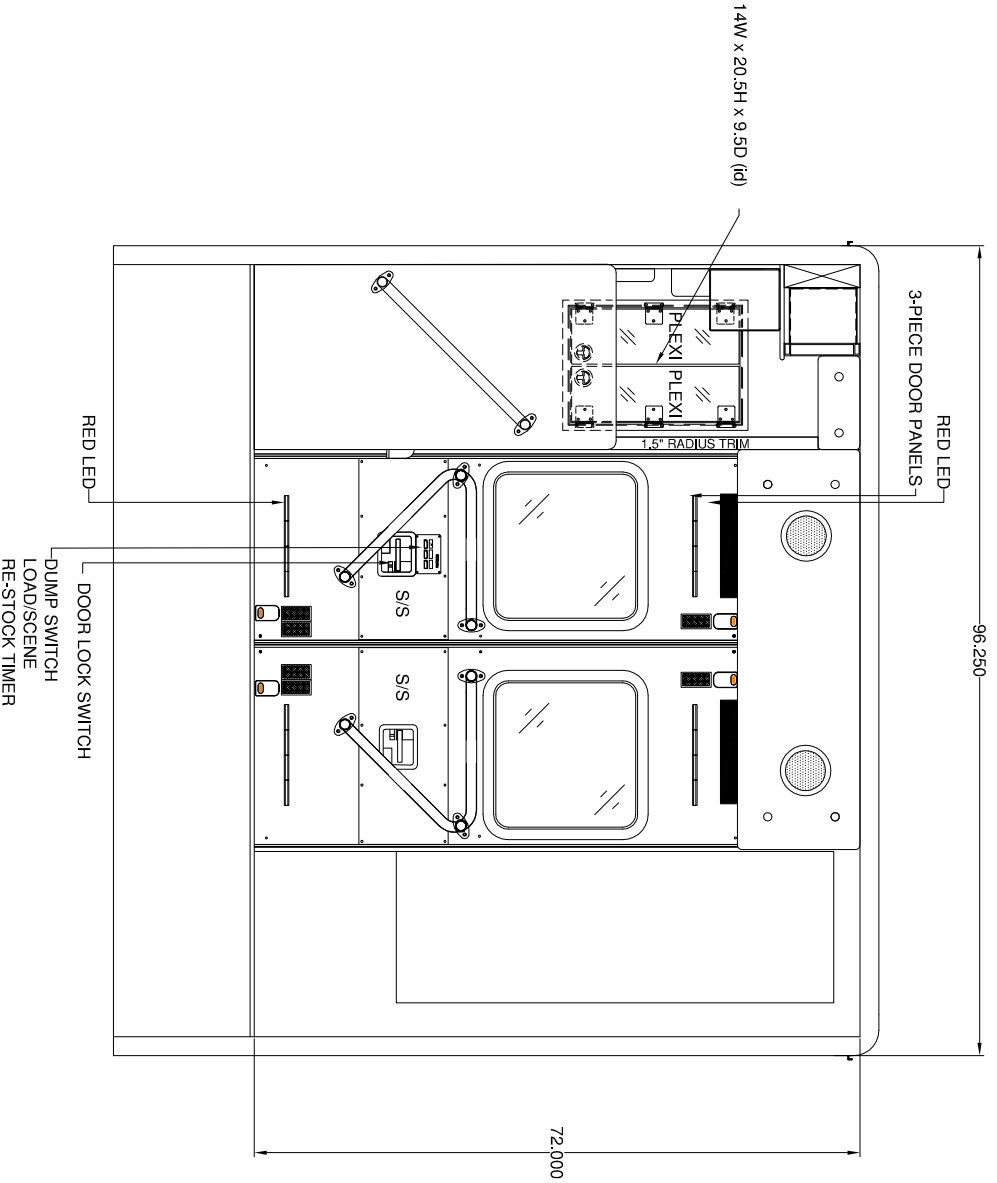

NOTE: DRAWINGS ARE FOR GRAPHICAL REPRESENTATION ONLY. DIMENSIONS ARE APPROXIMATE & MAY VARY DURING CONSTRUCTION.

PROPOSAL DRAWING

17712-112

Prepared for:
Mike Harper
REV GROUP__HORTON
EMERGENCY VEHICLES
3800 McDowell Rd
Grove City, OH 43123
Phone: 614-539-8181 Ex 316

Prepared by:
Mark Mims
PREMIER TRUCK GROUP OF
DALLAS
4200 PORT BOULEVARD
DALLAS, TX 75241
Phone: 972-225-4360

A proposal for
REV GROUP__HORTON EMERGENCY VEHICLES

Prepared by
PREMIER TRUCK GROUP OF DALLAS
Mark Mims

Jan 17, 2018

**2019 Freightliner M2 106
Marin County Fire
Quote Price \$85,668.00**

Quote PTGHOR055-A



Components shown may not reflect all spec'd options and are not to scale



Prepared for:
 Mike Harper
 REV GROUP_HORTON
 EMERGENCY VEHICLES
 3800 McDowell Rd
 Grove City, OH 43123
 Phone: 614-539-8181 Ex 316

Prepared by:
 Mark Mims
 PREMIER TRUCK GROUP OF
 DALLAS
 4200 PORT BOULEVARD
 DALLAS, TX 75241
 Phone: 972-225-4360

Q U O T A T I O N

M2 106 CONVENTIONAL CHASSIS

SET BACK AXLE - TRUCK	DETROIT DA-F-8.0-3 8,000# FF1 71.5 KPI/3.74 DROP
CUM B6.7 280EV HP @ 2400 RPM, 2600 GOV, 660 LB/FT @ 1600 RPM, R/F/E/	SINGLE FRONT AXLE
ALLISON 2200 EVS AUTOMATIC TRANSMISSION WITH PARK PAWL WITH PTO PROVISION	8,000# TAPERLEAF FRONT SUSPENSION
DETROIT DA-RS-17.5-2 17,500# R-SERIES SINGLE REAR AXLE	106 INCH BBC FLAT ROOF ALUMINUM CONVENTIONAL CAB
AIRLINER 12,000# REAR SUSPENSION	3875MM (153 INCH) WHEELBASE
	9/32X3-7/16X10-1/16 INCH STEEL FRAME (7.14MMX255.6/0.281X10.06 INCH) 80KSI
	1600MM (63 INCH) REAR FRAME OVERHANG

			PER UNIT		TOTAL
VEHICLE PRICE	TOTAL # OF UNITS (1)	\$	74,978	\$	74,978
EXTENDED WARRANTY		\$	200	\$	200
DEALER INSTALLED OPTIONS		\$	10,490	\$	10,490
CUSTOMER PRICE BEFORE TAX		\$	85,668	\$	85,668

TAXES AND FEES

TAXES AND FEES	\$	0	\$	0
OTHER CHARGES	\$	0	\$	0

TRADE-IN

TRADE-IN ALLOWANCE	\$	(0)	\$	(0)
--------------------	----	-----	----	-----

BALANCE DUE	(LOCAL CURRENCY)	\$	85,668	\$	85,668
--------------------	-------------------------	-----------	---------------	-----------	---------------

COMMENTS:

Projected delivery on ___ / ___ / ___ provided the order is received before ___ / ___ / ___.

APPROVAL:

Please indicate your acceptance of this quotation by signing below:

Customer: X _____ Date: ___ / ___ / ___.



Financing that works for you.

See your local dealer for a competitive quote from Daimler Truck Financial, or contact us at Information@dtfoffers.com.

Daimler Truck Financial offers a variety of finance, lease and insurance solutions to fit your business needs. For more information about our products and services, visit our website at www.daimler-truckfinancial.com.



Prepared for:
 Mike Harper
 REV GROUP__HORTON
 EMERGENCY VEHICLES
 3800 McDowell Rd
 Grove City, OH 43123
 Phone: 614-539-8181 Ex 316

Prepared by:
 Mark Mims
 PREMIER TRUCK GROUP OF
 DALLAS
 4200 PORT BOULEVARD
 DALLAS, TX 75241
 Phone: 972-225-4360

S P E C I F I C A T I O N P R O P O S A L

Data Code	Description	Retail Price
Price Level		
PRL-16M	M2 PRL-16M (EFF:04/25/17)	N/C
Data Version		
DRL-007	SPECPRO21 DATA RELEASE VER 007	N/C
Interior Convenience/Driver Retention Package		
055-002	INTERIOR CONVENIENCE PACKAGE	\$340.00
Vehicle Configuration		
001-172	M2 106 CONVENTIONAL CHASSIS	\$100,916.00
004-219	2019 MODEL YEAR SPECIFIED	N/C
002-004	SET BACK AXLE - TRUCK	STD
019-002	STRAIGHT TRUCK PROVISION	STD
003-001	LH PRIMARY STEERING LOCATION	STD
General Service		
AA1-002	TRUCK CONFIGURATION	STD
AA6-001	DOMICILED, USA 50 STATES (INCLUDING CALIFORNIA AND CARB OPT-IN STATES)	N/C
A85-006	RESCUE AND EMERGENCY SERVICE	N/C
A84-1EV	EMERGENCY VEHICLES BUSINESS SEGMENT	N/C
AA4-011	FIXED LOAD COMMODITY	N/C
AA5-002	TERRAIN/DUTY: 100% (ALL) OF THE TIME, IN TRANSIT, IS SPENT ON PAVED ROADS	STD
AB1-008	MAXIMUM 8% EXPECTED GRADE	STD
AB5-001	SMOOTH CONCRETE OR ASPHALT PAVEMENT - MOST SEVERE IN-TRANSIT (BETWEEN SITES) ROAD SURFACE	STD
995-091	MEDIUM TRUCK WARRANTY	STD
A66-99D	EXPECTED FRONT AXLE(S) LOAD : 8000.0 lbs.	
A68-99D	EXPECTED REAR DRIVE AXLE(S) LOAD : 12000.0 lbs.	

Application Version 9.3.011
 Data Version PRL-16M.007
 Marin County Fire - PTGHOR055-A
 BTR Fuel Spec



01/17/2018 10:32 AM

Page 3 of 23

Prepared for:
 Mike Harper
 REV GROUP__HORTON
 EMERGENCY VEHICLES
 3800 McDowell Rd
 Grove City, OH 43123
 Phone: 614-539-8181 Ex 316

Prepared by:
 Mark Mims
 PREMIER TRUCK GROUP OF
 DALLAS
 4200 PORT BOULEVARD
 DALLAS, TX 75241
 Phone: 972-225-4360

Data Code	Description	Retail Price
A63-99D	EXPECTED GROSS VEHICLE WEIGHT CAPACITY : 20000.0 lbs.	
* A70-99D	EXPECTED GROSS COMBINATION WEIGHT : 0.0 lbs.	

Truck Service

AA3-024	AMBULANCE BODY	N/C
A88-99D	EXPECTED TRUCK BODY LENGTH : 13.08 ft.	
AF3-212	HORTON EMERGENCY VEHICLES	N/C
RTK-1AA	APPROVAL TO SHARE SPEC WITH TEM	N/C
AF7-99D	EXPECTED BODY/PAYLOAD CG HEIGHT ABOVE FRAME "XX" INCHES : 32.0 in	

Engine

101-22B	CUM B6.7 280EV HP @ 2400 RPM, 2600 GOV, 660 LB/FT @ 1600 RPM, R/F/E/	\$5,595.00
---------	--	------------

Electronic Parameters

79A-075	75 MPH ROAD SPEED LIMIT	N/C
79B-000	CRUISE CONTROL SPEED LIMIT SAME AS ROAD SPEED LIMIT	N/C
79K-007	PTO MODE ENGINE RPM LIMIT - 1100 RPM	N/C
79M-001	PTO MODE BRAKE OVERRIDE - SERVICE BRAKE APPLIED	N/C
79P-002	PTO RPM WITH CRUISE SET SWITCH - 700 RPM	N/C
79Q-003	PTO RPM WITH CRUISE RESUME SWITCH - 800 RPM	N/C
79S-001	PTO MODE CANCEL VEHICLE SPEED - 5 MPH	N/C
79U-007	PTO GOVERNOR RAMP RATE - 250 RPM PER SECOND	N/C
80G-002	PTO MINIMUM RPM - 700	N/C
80J-002	REGEN INHIBIT SPEED THRESHOLD - 5 MPH	N/C

Engine Equipment

99C-017	2016 ONBOARD DIAGNOSTICS/2010 EPA/CARB/FINAL GHG17 CONFIGURATION	STD
99D-012	2008 CARB EMISSION CERTIFICATION - EXEMPTED VEHICLE; NO CLEAN IDLE LABEL REQUIRED	N/C
13E-001	STANDARD OIL PAN	STD
105-001	ENGINE MOUNTED OIL CHECK AND FILL	STD
133-004	ONE PIECE VALVE COVER	STD



Prepared for:
 Mike Harper
 REV GROUP__HORTON
 EMERGENCY VEHICLES
 3800 McDowell Rd
 Grove City, OH 43123
 Phone: 614-539-8181 Ex 316

Prepared by:
 Mark Mims
 PREMIER TRUCK GROUP OF
 DALLAS
 4200 PORT BOULEVARD
 DALLAS, TX 75241
 Phone: 972-225-4360

Data Code	Description	Retail Price
014-1B5	SIDE OF HOOD AIR INTAKE WITH DONALDSON HIGH CAPACITY AIR CLEANER WITH SAFETY ELEMENT, FIREWALL MOUNTED	\$46.00
124-1CE	LN 12V 320 AMP 4962PA PAD MOUNT ALTERNATOR	\$906.00
292-058	(3) ALLIANCE MODEL 1031, GROUP 31, 12 VOLT MAINTENANCE FREE 2280 CCA THREADED STUD BATTERIES	\$232.00
290-017	BATTERY BOX FRAME MOUNTED	STD
281-001	STANDARD BATTERY JUMPERS	STD
282-042	LH BATTERY BOX MOUNTED AS FAR AFT AS POSSIBLE, NO GREATER THAN 60 INCHES BACK OF CAB	\$231.00
291-017	WIRE GROUND RETURN FOR BATTERY CABLES WITH ADDITIONAL FRAME GROUND RETURN	STD
289-001	NON-POLISHED BATTERY BOX COVER	STD
295-029	POSITIVE AND NEGATIVE POSTS FOR JUMPSTART LOCATED ON FRAME NEXT TO STARTER	\$92.00
107-032	CUMMINS TURBOCHARGED 18.7 CFM AIR COMPRESSOR WITH INTERNAL SAFETY VALVE	STD
108-002	STANDARD MECHANICAL AIR COMPRESSOR GOVERNOR	STD
131-013	AIR COMPRESSOR DISCHARGE LINE	STD
152-039	GVG, FIRE AND EMERGENCY SERVICE VEHICLES ENGINE WARNING	N/C
128-1AR	CUMMINS EXHAUST BRAKE INTEGRAL WITH VARIABLE GEOMETRY TURBO WITH ON/OFF DASH SWITCH, ACTIVATES STOP LAMPS	\$35.00
016-1DD	RH OUTBOARD UNDER STEP MOUNTED HORIZONTAL AFTERTREATMENT SYSTEM ASSEMBLY WITH LH HORIZONTAL TAILPIPE EXITING FORWARD OF REAR TIRES	\$391.00
28F-007	ENGINE AFTERTREATMENT DEVICE, AUTOMATIC OVER THE ROAD ACTIVE REGENERATION AND DASH MOUNTED SINGLE REGENERATION REQUEST/INHIBIT SWITCH	N/C
239-001	STANDARD EXHAUST SYSTEM LENGTH	STD
237-027	LH HORIZONTAL TAILPIPE, EXIT FORWARD OF REAR TIRES	N/C
* 23U-001	6 GALLON DIESEL EXHAUST FLUID TANK	STD
30N-003	100 PERCENT DIESEL EXHAUST FLUID FILL	STD
43X-002	LH MEDIUM DUTY STANDARD DIESEL EXHAUST FLUID TANK LOCATION	STD

Application Version 9.3.011
 Data Version PRL-16M.007
 Marin County Fire - PTGHOR055-A
 BTR Fuel Spec



01/17/2018 10:32 AM

Page 5 of 23

Prepared for:
 Mike Harper
 REV GROUP__HORTON
 EMERGENCY VEHICLES
 3800 McDowell Rd
 Grove City, OH 43123
 Phone: 614-539-8181 Ex 316

Prepared by:
 Mark Mims
 PREMIER TRUCK GROUP OF
 DALLAS
 4200 PORT BOULEVARD
 DALLAS, TX 75241
 Phone: 972-225-4360

Data Code	Description	Retail Price
23Y-001	STANDARD DIESEL EXHAUST FLUID PUMP MOUNTING	STD
43Y-001	STANDARD DIESEL EXHAUST FLUID TANK CAP	STD
273-035	HORTON HT650 FRONTAL AIR ON/OFF ENGINE FAN CLUTCH	STD
276-002	AUTOMATIC FAN CONTROL WITH DASH SWITCH AND INDICATOR LIGHT, NON ENGINE MOUNTED	\$10.00
110-003	CUMMINS SPIN ON FUEL FILTER	STD
118-001	FULL FLOW OIL FILTER	STD
266-078	950 SQUARE INCH ALUMINUM RADIATOR	STD
103-036	ANTIFREEZE TO -34F, ETHYLENE GLYCOL PRE-CHARGED SCA HEAVY DUTY COOLANT	\$18.00
171-007	GATES BLUE STRIPE COOLANT HOSES OR EQUIVALENT	STD
172-001	CONSTANT TENSION HOSE CLAMPS FOR COOLANT HOSES	STD
270-016	RADIATOR DRAIN VALVE	STD
168-002	LOWER RADIATOR GUARD	STD
138-010	PHILLIPS-TEMRO 750 WATT/115 VOLT BLOCK HEATER	\$108.00
140-022	CHROME ENGINE HEATER RECEPTACLE MOUNTED UNDER LH DOOR	\$21.00
134-001	ALUMINUM FLYWHEEL HOUSING	STD
132-004	ELECTRIC GRID AIR INTAKE WARMER	STD
155-058	DELCO 12V 38MT HD STARTER WITH INTEGRATED MAGNETIC SWITCH	\$43.00

Transmission

342-1MR	ALLISON 2200 EVS AUTOMATIC TRANSMISSION WITH PARK PAWL WITH PTO PROVISION	\$1,220.00
---------	---	------------

Transmission Equipment

343-303	ALLISON VOCATIONAL PACKAGE 364 - AVAILABLE ON 1000/2000 PRODUCT FAMILIES WITH VOCATIONAL MODEL EVS	N/C
84B-003	ALLISON VOCATIONAL RATING FOR FIRE TRUCK/EMERGENCY VEHICLE APPLICATIONS AVAILABLE WITH ALL PRODUCT FAMILIES	N/C
84C-003	PRIMARY MODE GEARS, 5 FORWARD GEARS WITH MANUAL SELECTION FOR 3, 2 AND 1, AVAILABLE FOR 1000/2000 PRODUCT FAMILIES ONLY	STD



Prepared for:
 Mike Harper
 REV GROUP__HORTON
 EMERGENCY VEHICLES
 3800 McDowell Rd
 Grove City, OH 43123
 Phone: 614-539-8181 Ex 316

Prepared by:
 Mark Mims
 PREMIER TRUCK GROUP OF
 DALLAS
 4200 PORT BOULEVARD
 DALLAS, TX 75241
 Phone: 972-225-4360

Data Code	Description	Retail Price
84E-000	PRIMARY SHIFT SCHEDULE RECOMMENDED BY DTNA AND ALLISON, THIS DEFINED BY ENGINE AND VOCATIONAL USAGE	STD
84F-000	SECONDARY SHIFT SCHEDULE RECOMMENDED BY DTNA AND ALLISON, THIS DEFINED BY ENGINE AND VOCATIONAL USAGE	STD
84G-000	PRIMARY SHIFT SPEED RECOMMENDED BY DTNA AND ALLISON, THIS DEFINED BY ENGINE AND VOCATIONAL USAGE	STD
84H-000	SECONDARY SHIFT SPEED RECOMMENDED BY DTNA AND ALLISON, THIS DEFINED BY ENGINE AND VOCATIONAL USAGE	STD
84L-000	LOAD BASED SHIFT SCHEDULE AND VEHICLE ACCELERATION CONTROL RECOMMENDED BY DTNA AND ALLISON, THIS DEFINED VOCATIONAL USAGE	STD
84N-000	NEUTRAL AT STOP - DISABLED, FUELSENSE - DISABLED	STD
84U-000	DRIVER SWITCH INPUT - DEFAULT - NO SWITCHES	STD
353-022	VEHICLE INTERFACE WIRING CONNECTOR WITHOUT BLUNT CUTS, AT BACK OF CAB	\$49.00
34C-001	ELECTRONIC TRANSMISSION CUSTOMER ACCESS CONNECTOR FIREWALL MOUNTED	\$25.00
341-018	MAGNETIC PLUGS, ENGINE DRAIN, TRANSMISSION DRAIN, AXLE(S) FILL AND DRAIN	STD
345-074	DASH MOUNTED T-HANDLE CABLE SHIFT CONTROL WITH PARK POSITION FOR INTERNAL PARK PAWL	N/C
97G-006	TRANSMISSION PROGNOSTICS - DISABLED (N/A) 2013, FOR USE IN 1000/2000 ONLY	STD
370-015	WATER TO OIL TRANSMISSION COOLER, IN RADIATOR END TANK	STD
346-001	TRANSMISSION OIL CHECK AND FILL	STD
35T-001	SYNTHETIC TRANSMISSION FLUID (TES-295 COMPLIANT)	STD

Front Axle and Equipment

400-1EW	DETROIT DA-F-8.0-3 8,000# FF1 71.5 KPI/3.74 DROP SINGLE FRONT AXLE	(\$31.00)
402-021	MERITOR 15X5 Q+ CAST SPIDER CAM FRONT BRAKES, DOUBLE ANCHOR, FABRICATED SHOES	\$119.00

Application Version 9.3.011
 Data Version PRL-16M.007
 Marin County Fire - PTGHOR055-A
 BTR Fuel Spec



01/17/2018 10:32 AM

Page 7 of 23

Prepared for:
 Mike Harper
 REV GROUP__HORTON
 EMERGENCY VEHICLES
 3800 McDowell Rd
 Grove City, OH 43123
 Phone: 614-539-8181 Ex 316

Prepared by:
 Mark Mims
 PREMIER TRUCK GROUP OF
 DALLAS
 4200 PORT BOULEVARD
 DALLAS, TX 75241
 Phone: 972-225-4360

Data Code	Description	Retail Price
403-026	FIRE AND EMERGENCY SEVERE SERVICE, NON-ASBESTOS FRONT LINING	\$43.00
419-023	CONMET CAST IRON FRONT BRAKE DRUMS	STD
409-006	FRONT OIL SEALS	STD
408-001	VENTED FRONT HUB CAPS WITH WINDOW, CENTER AND SIDE PLUGS - OIL	STD
416-022	STANDARD SPINDLE NUTS FOR ALL AXLES	STD
405-003	HALDEX AUTOMATIC FRONT SLACK ADJUSTERS	\$51.00
536-050	TRW THP-60 POWER STEERING	STD
539-003	POWER STEERING PUMP	STD
534-015	2 QUART SEE THROUGH POWER STEERING RESERVOIR	STD
40T-001	ORGANIC SAE 80/90 FRONT AXLE LUBE	STD
Front Suspension		
620-032	8,000# TAPERLEAF FRONT SUSPENSION	(\$21.00)
619-005	MAINTENANCE FREE RUBBER BUSHINGS - FRONT SUSPENSION	STD
* 62G-007	355MM FRONT SUSPENSION WHEEL HEIGHT	\$56.00
629-004	FRONT SWAYBAR	\$464.00
410-001	FRONT SHOCK ABSORBERS	STD
Rear Axle and Equipment		
420-1C6	DETROIT DA-RS-17.5-2 17,500# R-SERIES SINGLE REAR AXLE	(\$352.00)
421-410	4.10 REAR AXLE RATIO	N/C
424-001	IRON REAR AXLE CARRIER WITH STANDARD AXLE HOUSING	STD
386-079	MXL 16T MERITOR EXTENDED LUBE MAIN DRIVELINE WITH HALF ROUND YOKES	(\$371.00)
423-028	MERITOR 15X8.62 Q+ CAST SPIDER CAM REAR BRAKES, DOUBLE ANCHOR, FABRICATED SHOES	\$156.00
433-025	FIRE AND EMERGENCY SEVERE SERVICE NON-ASBESTOS REAR BRAKE LINING	N/C
434-005	BRAKE CAMS AND CHAMBERS ON FORWARD SIDE OF DRIVE AXLE(S) WITH AUXILIARY SUPPORT BRACKETS	STD
451-023	CONMET CAST IRON REAR BRAKE DRUMS	STD
440-006	REAR OIL SEALS	STD



Prepared for:
 Mike Harper
 REV GROUP__HORTON
 EMERGENCY VEHICLES
 3800 McDowell Rd
 Grove City, OH 43123
 Phone: 614-539-8181 Ex 316

Prepared by:
 Mark Mims
 PREMIER TRUCK GROUP OF
 DALLAS
 4200 PORT BOULEVARD
 DALLAS, TX 75241
 Phone: 972-225-4360

Data Code	Description	Retail Price
* 426-074	HALDEX GOLDSEAL LONGSTROKE 1-DRIVE AXLE SPRING PARKING CHAMBERS	N/C
428-003	HALDEX AUTOMATIC REAR SLACK ADJUSTERS	\$46.00
41T-001	ORGANIC SAE 80/90 REAR AXLE LUBE	STD

Rear Suspension

* 622-1CX	AIRLINER 12,000# REAR SUSPENSION	\$6.00
621-046	AIRLINER MID POSITION RIDE HEIGHT	N/C
431-001	STANDARD AXLE SEATS IN AXLE CLAMP GROUP	STD
910-004	DUAL AIR REAR SUSPENSION LEVELING VALVES	\$83.00
623-002	TRANSVERSE CONTROL RODS	STD
439-004	REAR SHOCK ABSORBERS - ONE AXLE (AIR RIDE SUSPENSION)	STD

Brake System

018-002	AIR BRAKE PACKAGE	STD
490-100	WABCO 4S/4M ABS WITHOUT TRACTION CONTROL	STD
871-001	REINFORCED NYLON, FABRIC BRAID AND WIRE BRAID CHASSIS AIR LINES	STD
904-001	FIBER BRAID PARKING BRAKE HOSE	STD
412-001	STANDARD BRAKE SYSTEM VALVES	STD
46D-002	STANDARD AIR SYSTEM PRESSURE PROTECTION SYSTEM	STD
413-002	STD U.S. FRONT BRAKE VALVE	STD
432-003	RELAY VALVE WITH 5-8 PSI CRACK PRESSURE, NO REAR PROPORTIONING VALVE	STD
480-086	BW AD-9SI BRAKE LINE AIR DRYER WITH HEATER	N/C
479-012	AIR DRYER MOUNTED UNDER HOOD	N/C
460-008	STEEL AIR BRAKE RESERVOIRS MOUNTED INSIDE RAIL	\$20.00
607-001	CLEAR FRAME RAILS FROM BACK OF CAB TO FRONT REAR SUSPENSION BRACKET, BOTH RAILS OUTBOARD	\$63.00
477-006	BW DV-2 AUTO DRAIN VALVE WITHOUT HEATER ON ALL TANK(S)	\$82.00

Trailer Connections

335-004	UPGRADED CHASSIS MULTIPLEXING UNIT	STD
32A-002	UPGRADED BULKHEAD MULTIPLEXING UNIT	STD

Application Version 9.3.011
 Data Version PRL-16M.007
 Marin County Fire - PTGHOR055-A
 BTR Fuel Spec



01/17/2018 10:32 AM

Page 9 of 23

Prepared for:
 Mike Harper
 REV GROUP__HORTON
 EMERGENCY VEHICLES
 3800 McDowell Rd
 Grove City, OH 43123
 Phone: 614-539-8181 Ex 316

Prepared by:
 Mark Mims
 PREMIER TRUCK GROUP OF
 DALLAS
 4200 PORT BOULEVARD
 DALLAS, TX 75241
 Phone: 972-225-4360

Data Code	Description	Retail Price
Wheelbase & Frame		
545-387	3875MM (153 INCH) WHEELBASE	N/C
546-094	9/32X3-7/16X10-1/16 INCH STEEL FRAME (7.14MMX255.6/0.281X10.06 INCH) 80KSI	STD
552-030	1600MM (63 INCH) REAR FRAME OVERHANG	STD
55W-006	FRAME OVERHANG RANGE: 61 INCH TO 70 INCH	N/C
AC8-99D	CALC'D BACK OF CAB TO REAR SUSP C/L (CA) : 87.45 in	
AE8-99D	CALCULATED EFFECTIVE BACK OF CAB TO REAR SUSPENSION C/L (CA) : 84.45 in	
AE4-99D	CALC'D FRAME LENGTH - OVERALL : 245.39	
AM6-99D	CALC'D SPACE AVAILABLE FOR DECKPLATE : 87.45 in	
FSS-0LH	CALCULATED FRAME SPACE LH SIDE : 74.63 in	N/C
FSS-0RH	CALCULATED FRAME SPACE RH SIDE : 76.82 in	N/C
553-001	SQUARE END OF FRAME	STD
550-001	FRONT CLOSING CROSSMEMBER	STD
559-001	STANDARD WEIGHT ENGINE CROSSMEMBER	STD
562-001	STANDARD MIDSHIP #1 CROSSMEMBER(S)	STD
572-001	STANDARD REAR MOST CROSSMEMBER	STD
565-001	STANDARD SUSPENSION CROSSMEMBER	STD
Chassis Equipment		
556-1AR	THREE-PIECE 14 INCH CHROMED STEEL BUMPER WITH COLLAPSIBLE ENDS	\$377.00
558-001	FRONT TOW HOOKS - FRAME MOUNTED	\$74.00
574-001	BUMPER MOUNTING FOR SINGLE LICENSE PLATE	STD
586-024	FENDER AND FRONT OF HOOD MOUNTED FRONT MUDFLAPS	STD
* 551-017	GRADE 8 THREADED HEX HEADED FRAME FASTENERS INSTALLED WITH BOLT HEADS ON OUTSIDE OF FRAME	N/C
Fuel Tanks		
	204-998 NO LH FUEL TANK	(\$491.00)
N	230-043 40 GALLON/151 LITER RECTANGULAR STEEL FUEL TANK - BETWEEN RAILS	\$778.00
	218-005 RECTANGULAR FUEL TANK(S)	STD
	215-009 PAINTED FUEL TANK(S), PAINTED STRAPS WITH RUBBER ISOLATORS	N/C

Application Version 9.3.011
 Data Version PRL-16M.007
 Marin County Fire - PTGHOR055-A
 BTR Fuel Spec



01/17/2018 10:32 AM

Page 10 of 23

Prepared for:
 Mike Harper
 REV GROUP__HORTON
 EMERGENCY VEHICLES
 3800 McDowell Rd
 Grove City, OH 43123
 Phone: 614-539-8181 Ex 316

Prepared by:
 Mark Mims
 PREMIER TRUCK GROUP OF
 DALLAS
 4200 PORT BOULEVARD
 DALLAS, TX 75241
 Phone: 972-225-4360

Data Code	Description	Retail Price
231-004	FUEL TANK(S) MOUNTED BETWEEN RAILS AFT OF REAR AXLE	N/C
664-001	PLAIN STEP FINISH	STD
205-060	LH SIDEFILL FUEL TANK PREP CAP	\$7.00
122-1J2	DETROIT FUEL/WATER SEPARATOR WITH WATER IN FUEL SENSOR AND HAND PRIMER	STD
216-001	SINGLE SUCTION AND RETURN FUEL LINES	\$36.00
20E-001	AUXILIARY FUEL SUPPLY AND RETURN PORTS	\$186.00
202-016	HIGH TEMPERATURE REINFORCED NYLON FUEL LINE	STD
Tires		
093-0E5	MICHELIN XZE 245/70R19.5 16 PLY RADIAL FRONT TIRES	(\$466.00)
094-0E5	MICHELIN XZE 245/70R19.5 16 PLY RADIAL REAR TIRES	(\$932.00)
Hubs		
418-060	CONMET PRESET PLUS PREMIUM IRON FRONT HUBS	\$123.00
450-060	CONMET PRESET PLUS PREMIUM IRON REAR HUBS	\$128.00
Wheels		
502-1E5	ALCOA 77362X 19.5X7.50 10-HUB PILOT 5.23 INSET ALUMINUM DISC FRONT WHEELS	\$440.00
505-1E5	ALCOA 77362X 19.5X7.50 10-HUB PILOT ALUMINUM DISC REAR WHEELS	\$880.00
524-001	POLISHED FRONT WHEELS; OUTSIDE ONLY	\$58.00
525-001	POLISHED REAR WHEELS; OUTSIDE OF OUTER WHEELS ONLY	\$60.00
*	52M-004 FORCEMATCH TIRE/WHEEL RUNOUT CHECK/MARK AND STATIC BALANCING - ALL TIRES/WHEELS	\$127.00
496-011	FRONT WHEEL MOUNTING NUTS	STD
497-011	REAR WHEEL MOUNTING NUTS	STD
Cab Exterior		
829-071	106 INCH BBC FLAT ROOF ALUMINUM CONVENTIONAL CAB	STD
650-009	RUBBER CAB MOUNTS	STD
705-012	CAB ROOF REINFORCEMENTS FOR ROOF MOUNTED COMPONENTS	\$49.00



Prepared for:
 Mike Harper
 REV GROUP__HORTON
 EMERGENCY VEHICLES
 3800 McDowell Rd
 Grove City, OH 43123
 Phone: 614-539-8181 Ex 316

Prepared by:
 Mark Mims
 PREMIER TRUCK GROUP OF
 DALLAS
 4200 PORT BOULEVARD
 DALLAS, TX 75241
 Phone: 972-225-4360

Data Code	Description	Retail Price
678-018	LH AND RH EXTERIOR GRAB HANDLES WITH SINGLE RUBBER INSERT	\$59.00
646-023	HOOD MOUNTED CHROMED PLASTIC GRILLE	\$97.00
65X-003	CHROME HOOD MOUNTED AIR INTAKE GRILLE	\$49.00
644-004	FIBERGLASS HOOD	STD
690-002	TUNNEL/FIREWALL LINER	\$35.00
727-1B1	DUAL 25 INCH ROUND STUTTER TONE HOOD MOUNTED AIR HORNS WITH DUAL LANYARDS	\$607.00
726-002	DUAL ELECTRIC HORNS	\$10.00
728-002	DUAL HORN SHIELDS	N/C
657-1CV	DOOR LOCKS AND IGNITION SWITCH KEYED THE SAME WITH (4) KEYS	\$19.00
575-001	REAR LICENSE PLATE MOUNT END OF FRAME	STD
312-038	INTEGRAL HEADLIGHT/MARKER ASSEMBLY WITH CHROME BEZEL	N/C
302-047	LED AERODYNAMIC MARKER LIGHTS	\$34.00
311-019	HEADLIGHTS ON WITH WIPERS, WITH DAYTIME RUNNING LIGHTS	\$40.00
294-094	OMIT STOP/TAIL/BACKUP LIGHTS AND PROVIDE WIRING WITH SEPARATE STOP/TAIL WIRES TO 7 FEET BEYOND END OF FRAME	(\$52.00)
300-015	STANDARD FRONT TURN SIGNAL LAMPS	STD
744-1BC	DUAL WEST COAST BRIGHT FINISH HEATED MIRRORS WITH LH AND RH REMOTE	\$286.00
797-001	DOOR MOUNTED MIRRORS	STD
796-001	102 INCH EQUIPMENT WIDTH	STD
743-204	LH AND RH 8 INCH BRIGHT FINISH CONVEX MIRRORS MOUNTED UNDER PRIMARY MIRRORS	N/C
74A-001	RH DOWN VIEW MIRROR	\$21.00
729-001	STANDARD SIDE/REAR REFLECTORS	STD
275-063	2-STAGE ELECTRIC HORN AND HAZARD LAMP ALERT CONTROLLED BY PARTICULATE FILTER REGENERATION REQUIRED STATUS	N/C
768-998	NO REAR WINDOW	\$35.00
661-004	TINTED DOOR GLASS LH AND RH WITH TINTED OPERATING WING WINDOWS	\$122.00
654-027	RH AND LH ELECTRIC POWERED WINDOWS, PASSENGER SWITCHES ON DOOR(S)	\$218.00
663-019	1-PIECE TINTED ROPED-IN WINDSHIELD	\$22.00



Prepared for:
 Mike Harper
 REV GROUP__HORTON
 EMERGENCY VEHICLES
 3800 McDowell Rd
 Grove City, OH 43123
 Phone: 614-539-8181 Ex 316

Prepared by:
 Mark Mims
 PREMIER TRUCK GROUP OF
 DALLAS
 4200 PORT BOULEVARD
 DALLAS, TX 75241
 Phone: 972-225-4360

Data Code	Description	Retail Price
659-019	2 GALLON WINDSHIELD WASHER RESERVOIR WITHOUT FLUID LEVEL INDICATOR, FRAME MOUNTED	STD
Cab Interior		
707-1AK	OPAL GRAY VINYL INTERIOR	N/C
706-016	MOLDED DOOR PANEL WITH UPPER VINYL INSERTS	N/C
708-016	MOLDED DOOR PANEL WITH UPPER VINYL INSERTS	N/C
772-006	BLACK MATS WITH SINGLE INSULATION	STD
691-014	FORWARD ROOF MOUNTED CONSOLE WITH UPPER STORAGE COMPARTMENTS AND ADDITIONAL CENTER COMPARTMENT WITHOUT NETTING	N/C
694-010	IN DASH STORAGE BIN	STD
693-008	PLASTIC MANIFEST BOX - LH AND RH DOORS	\$26.00
742-007	(2) CUP HOLDERS LH AND RH DASH	STD
680-006	GRAY/CHARCOAL FLAT DASH	STD
860-004	SMART SWITCH EXPANSION MODULE	\$198.00
700-002	HEATER, DEFROSTER AND AIR CONDITIONER	STD
701-001	STANDARD HVAC DUCTING	STD
703-005	MAIN HVAC CONTROLS WITH RECIRCULATION SWITCH	STD
170-015	STANDARD HEATER PLUMBING	STD
130-036	(1) DENSO HEAVY DUTY AND (1) SANDEN COMPACT REFRIGERANT COMPRESSORS	\$518.00
702-002	BINARY CONTROL, R-134A	STD
739-034	PREMIUM INSULATION	\$187.00
285-013	SOLID-STATE CIRCUIT PROTECTION AND FUSES	STD
280-007	12V NEGATIVE GROUND ELECTRICAL SYSTEM	STD
324-011	DOMED DOOR ACTIVATED LH AND RH, DUAL READING LIGHTS, FORWARD CAB ROOF	N/C
655-005	LH AND RH ELECTRIC DOOR LOCKS	\$99.00
284-101	(1) 12V POWER SUPPLY (1) DUAL 2.1 AMP USB CHARGER IN DASH	\$87.00
756-1D9	PREMIUM HIGH BACK AIR SUSPENSION DRIVER SEAT WITH 3 CHAMBER AIR LUMBAR, INTEGRATED CUSHION EXTENSION, FORWARD AND REAR CUSHION TILT, ADJUSTABLE SHOCK ABSORBER	\$418.00



Prepared for:
 Mike Harper
 REV GROUP__HORTON
 EMERGENCY VEHICLES
 3800 McDowell Rd
 Grove City, OH 43123
 Phone: 614-539-8181 Ex 316

Prepared by:
 Mark Mims
 PREMIER TRUCK GROUP OF
 DALLAS
 4200 PORT BOULEVARD
 DALLAS, TX 75241
 Phone: 972-225-4360

Data Code	Description	Retail Price
760-1D9	PREMIUM HIGH BACK AIR SUSPENSION PASSENGER SEAT WITH 3 CHAMBER AIR LUMBAR, INTEGRATED CUSHION EXTENSION, FORWARD AND REAR CUSHION TILT, ADJUSTABLE SHOCK ABSORBER	\$451.00
711-004	LH AND RH INTEGRAL DOOR PANEL ARMRESTS	STD
758-033	VINYL WITH CLOTH INSERT DRIVER SEAT	N/C
761-033	VINYL WITH CLOTH INSERT PASSENGER SEAT	(\$1.00)
763-104	HIGH VISIBILITY ORANGE SEAT BELTS WITH DRIVER INDICATOR LIGHT AND AUDIBLE ALARM	\$62.00
532-002	ADJUSTABLE TILT AND TELESCOPING STEERING COLUMN	\$478.00
540-015	4-SPOKE 18 INCH (450MM) STEERING WHEEL	STD
765-002	DRIVER AND PASSENGER INTERIOR SUN VISORS	STD

Instruments & Controls

732-003	WOODGRAIN DRIVER INSTRUMENT PANEL	N/C
734-003	WOODGRAIN CENTER INSTRUMENT PANEL	N/C
87L-003	ENGINE REMOTE INTERFACE WITH PARK BRAKE AND NEUTRAL INTERLOCKS	N/C
870-001	BLACK GAUGE BEZELS	STD
486-001	LOW AIR PRESSURE INDICATOR LIGHT AND AUDIBLE ALARM	STD
840-002	2 INCH PRIMARY AND SECONDARY AIR PRESSURE GAUGES	STD
198-003	DASH MOUNTED AIR RESTRICTION INDICATOR WITH GRADUATIONS	\$36.00
149-013	ELECTRONIC CRUISE CONTROL WITH SWITCHES IN LH SWITCH PANEL	STD
156-007	KEY OPERATED IGNITION SWITCH AND INTEGRAL START POSITION; 4 POSITION OFF/RUN/START/ACCESSORY	STD
811-042	ICU3S, 132X48 DISPLAY WITH DIAGNOSTICS, 28 LED WARNING LAMPS AND DATA LINKED	STD
160-038	HEAVY DUTY ONBOARD DIAGNOSTICS INTERFACE CONNECTOR LOCATED BELOW LH DASH	STD
844-001	2 INCH ELECTRIC FUEL GAUGE	STD
148-070	ENGINE REMOTE INTERFACE WITH PRESET FAST IDLE	\$85.00
163-004	ENGINE REMOTE INTERFACE CONNECTOR IN ENGINE COMPARTMENT	(\$16.00)



Prepared for:
 Mike Harper
 REV GROUP__HORTON
 EMERGENCY VEHICLES
 3800 McDowell Rd
 Grove City, OH 43123
 Phone: 614-539-8181 Ex 316

Prepared by:
 Mark Mims
 PREMIER TRUCK GROUP OF
 DALLAS
 4200 PORT BOULEVARD
 DALLAS, TX 75241
 Phone: 972-225-4360

Data Code	Description	Retail Price
856-001	ELECTRICAL ENGINE COOLANT TEMPERATURE GAUGE	STD
864-001	2 INCH TRANSMISSION OIL TEMPERATURE GAUGE	STD
830-017	ENGINE AND TRIP HOUR METERS INTEGRAL WITHIN DRIVER DISPLAY	STD
852-002	ELECTRIC ENGINE OIL PRESSURE GAUGE	STD
746-1B4	AM/FM/WB WORLD TUNER RADIO WITH CD PLAYER, BLUETOOTH, IPOD INTERFACE, USB AND AUXILIARY INPUTS, J1939	\$554.00
747-001	DASH MOUNTED RADIO	N/C
750-002	(2) RADIO SPEAKERS IN CAB	N/C
753-001	AM/FM ANTENNA MOUNTED ON FORWARD LH ROOF	N/C
810-027	ELECTRONIC MPH SPEEDOMETER WITH SECONDARY KPH SCALE, WITHOUT ODOMETER	STD
817-001	STANDARD VEHICLE SPEED SENSOR	STD
812-001	ELECTRONIC 3000 RPM TACHOMETER	STD
813-998	NO VEHICLE PERFORMANCE MONITOR	STD
162-002	IGNITION SWITCH CONTROLLED ENGINE STOP	N/C
81Y-001	PRE-TRIP LAMP INSPECTION, ALL OUTPUTS FLASH, WITH SMART SWITCH	\$12.00
264-032	(2) OVERHEAD MOUNTED LANYARD CONTROLS: (1) OFFICER AIR HORN AND (1) DRIVER AIR HORN	\$97.00
836-015	DIGITAL VOLTAGE DISPLAY INTEGRAL WITH DRIVER DISPLAY	STD
660-008	SINGLE ELECTRIC WINDSHIELD WIPER MOTOR WITH DELAY	STD
304-001	MARKER LIGHT SWITCH INTEGRAL WITH HEADLIGHT SWITCH	STD
27D-004	ALTERNATING FLASHING HEADLAMP SYSTEM WITH BODY BUILDER CONTROLLED ENGAGEMENT	N/C
882-009	ONE VALVE PARKING BRAKE SYSTEM WITH WARNING INDICATOR	STD
299-013	SELF CANCELING TURN SIGNAL SWITCH WITH DIMMER, WASHER/WIPER AND HAZARD IN HANDLE	STD
298-039	INTEGRAL ELECTRONIC TURN SIGNAL FLASHER WITH HAZARD LAMPS OVERRIDING STOP LAMPS	STD



Prepared for:
 Mike Harper
 REV GROUP__HORTON
 EMERGENCY VEHICLES
 3800 McDowell Rd
 Grove City, OH 43123
 Phone: 614-539-8181 Ex 316

Prepared by:
 Mark Mims
 PREMIER TRUCK GROUP OF
 DALLAS
 4200 PORT BOULEVARD
 DALLAS, TX 75241
 Phone: 972-225-4360

	Data Code	Description	Retail Price
Design			
*	065-902	TWO COLOR CUSTOM PAINT	\$1,426.00
Color			
*	980-MU8	CAB COLOR A: 00817EB BC	WHITE ELITE N/C
*	981-MC8	CAB COLOR B: M9041EB BC	RED ELITE N/C
	986-020	BLACK, HIGH SOLIDS POLYURETHANE CHASSIS PAINT	STD
	963-003	STANDARD E COAT/UNDERCOATING	STD
Certification / Compliance			
	996-001	U.S. FMVSS CERTIFICATION, EXCEPT SALES CABS AND GLIDER KITS	STD
Secondary Factory Options			
	99B-012	SHIP TO THIRD PARTY (CHARLOTTE, NC) PRIOR TO DELIVERY	\$225.00
	999-014	DEALER HAS BEEN ADVISED OF AND ACCEPTED RESPONSIBILITY FOR MODIFICATIONS DUE TO POSSIBLE PTO/CHASSIS INTERFERENCE	N/C
*	923-001	STANDARD ROUTING AND CLIPPING	N/C

T O T A L V E H I C L E S U M M A R Y

Adjusted List Price		Adjusted List Price **	\$118,670.00
----------------------------	--	------------------------	--------------

I T E M S N O T I N C L U D E D I N A D J U S T E D L I S T P R I C E

Other Factory Charges		
PMU-017	2016 OBD/2010 EPA/CARB/GHG17 ESCALATOR	\$300.00
P73-2FT	STANDARD DESTINATION CHARGE	\$2,050.00



Prepared for:
 Mike Harper
 REV GROUP__HORTON
 EMERGENCY VEHICLES
 3800 McDowell Rd
 Grove City, OH 43123
 Phone: 614-539-8181 Ex 316

Prepared by:
 Mark Mims
 PREMIER TRUCK GROUP OF
 DALLAS
 4200 PORT BOULEVARD
 DALLAS, TX 75241
 Phone: 972-225-4360

Extended Warranty

WAG-010	TOWING: 1 YEAR/UNLIMITED MILES/KM EXTENDED TOWING COVERAGE \$550 CAP FEX APPLIES	\$200.00
	Currency Exchange Rate	1.0000
	Total Extended Warranty (Local Currency)	\$200.00

Dealer Installed Options

		Weight Front	Weight Rear	Price
LSS 1	FURNISH & INSTALL LIQUID SPRING HYDRAULIC REAR SUSPENSION PACKAGE. IN-CAB CONTROL PAD TO	0	0	\$10,490.00
LSS 2	BE LEFT LOOSE FOR CUSTOMER INSTALLATION. WIRING TO TRIGGER KNEEL FUNCTION WILL BE BUNDLED AND TIE STRAPPED	0	0	STD
LSS 3	TO THE CONTROL MODULE UNDER THE FRAME RAIL.	0	0	STD
LSS 4	LIQUID SPRING REAR SUSPENSION INSTALLTION AT UPFITTER. LIQUID SPRING IS NOT A FREIGHTLINER OR DEALER	0	0	STD
LSS 5	INSTALLED OPTION AND IS NOT COVERED BY FREIGHTLINER WARRANTY, ANY LIQUID SPRING SERVICE NEEDS	0	0	STD
LSS 6	TO BE PROVIDED BY LIQUID SPRING AND OR THEIR DEALERS, CUSTOMER MUST ASSUME RESPONSIBILITY FOR ANY CHARGES	0	0	STD
	Total Dealer Installed Options	0 lbs.	0 lbs.	\$10,490.00

(**) Prices shown do not include taxes, fees, etc... "Net Equipment Selling Price" is located on the Quotation Details Proposal Report.



Prepared for:
 Mike Harper
 REV GROUP_HORTON
 EMERGENCY VEHICLES
 3800 McDowell Rd
 Grove City, OH 43123
 Phone: 614-539-8181 Ex 316

Prepared by:
 Mark Mims
 PREMIER TRUCK GROUP OF
 DALLAS
 4200 PORT BOULEVARD
 DALLAS, TX 75241
 Phone: 972-225-4360

D I M E N S I O N S

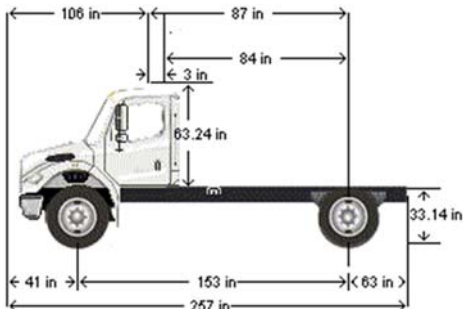

VEHICLE SPECIFICATIONS SUMMARY - DIMENSIONS

Model	M2106
Wheelbase (545).....	3875MM (153 INCH) WHEELBASE
Rear Frame Overhang (552).....	1600MM (63 INCH) REAR FRAME OVERHANG
Fifth Wheel (578)	NO FIFTH WHEEL
Mounting Location (577)	NO FIFTH WHEEL LOCATION
Maximum Forward Position (in)	0
Maximum Rearward Position (in).....	0
Amount of Slide Travel (in)	0
Slide Increment (in)	0
Desired Slide Position (in).....	0.0
Cab Size (829)	106 INCH BBC FLAT ROOF ALUMINUM CONVENTIONAL CAB
Sleeper (682)	NO SLEEPER BOX/SLEEPER CAB
Exhaust System (016).....	RH OUTBOARD UNDER STEP MOUNTED HORIZONTAL AFTERTREATMENT SYSTEM ASSEMBLY WITH LH HORIZONTAL TAILPIPE EXITING FORWARD OF REAR TIRES

TABLE SUMMARY - DIMENSIONS



Prepared for:
 Mike Harper
 REV GROUP_HORTON
 EMERGENCY VEHICLES
 3800 McDowell Rd
 Grove City, OH 43123
 Phone: 614-539-8181 Ex 316

Prepared by:
 Mark Mims
 PREMIER TRUCK GROUP OF
 DALLAS
 4200 PORT BOULEVARD
 DALLAS, TX 75241
 Phone: 972-225-4360

Dimensions	Inches
Bumper to Back of Cab (BBC)	106.3
Bumper to Centerline of Front Axle (BA)	40.7
Min. Cab to Body Clearance (CB)	3.0
Back of Cab to Centerline of Rear Axle(s) (CA)	87.4
Effective Back of Cab to Centerline of Rear Axle(s) (Effective CA)	84.4
Back of Cab Protrusions (Exhaust/Intake) (CP)	0.0
Back of Cab Protrusions (Side Extenders/Trim Tab) (CP)	0.0
Back of Cab Protrusions (CNG Tank)	0.0
Back of Cab Clearance (CL)	3.0
Back of Cab to End of Frame	150.4
Cab Height (CH)	63.2
Wheelbase (WB)	153.0
Frame Overhang (OH)	63.0
Overall Length (OAL)	256.7
Rear Axle Spacing	0.0
Unladen Frame Height at Centerline of Rear Axle	33.1

Performance calculations are estimates only. If performance calculations are critical, please contact Customer Application Engineering.



Prepared for:
 Mike Harper
 REV GROUP_HORTON
 EMERGENCY VEHICLES
 3800 McDowell Rd
 Grove City, OH 43123
 Phone: 614-539-8181 Ex 316

Prepared by:
 Mark Mims
 PREMIER TRUCK GROUP OF
 DALLAS
 4200 PORT BOULEVARD
 DALLAS, TX 75241
 Phone: 972-225-4360

G V W R

VEHICLE SPECIFICATIONS SUMMARY - GVWR

Model	M2106
Cab Size (829)	106 INCH BBC FLAT ROOF ALUMINUM CONVENTIONAL CAB
Expected Front Axle(s) Load (lbs.)	8000.0
Expected Pusher Axle(s) Load (lbs.)	0.0
Expected Rear Axle(s) Load (lbs.)	12000.0
Expected Tag Axle(s) Load (lbs.)	0.0
Expected GVW (lbs.)	20000
Expected GCW (lbs.)	0.0
Front Axle (400)	DETROIT DA-F-8.0-3 8,000# FF1 71.5 KPI/3.74 DROP SINGLE FRONT AXLE
Front Suspension (620)	8,000# TAPERLEAF FRONT SUSPENSION
Front Hubs (418)	CONMET PRESET PLUS PREMIUM IRON FRONT HUBS
Front Disc Wheels (502)	ALCOA 77362X 19.5X7.50 10-HUB PILOT 5.23 INSET ALUMINUM DISC FRONT WHEELS
Front Tires (093)	MICHELIN XZE 245/70R19.5 16 PLY RADIAL FRONT TIRES
Front Brakes (402)	MERITOR 15X5 Q+ CAST SPIDER CAM FRONT BRAKES, DOUBLE ANCHOR, FABRICATED SHOES
Steering Gear (536)	TRW THP-60 POWER STEERING
Rear Axle (420)	DETROIT DA-RS-17.5-2 17,500# R-SERIES SINGLE REAR AXLE
Rear Suspension (622)	AIRLINER 12,000# REAR SUSPENSION
Rear Hubs (450)	CONMET PRESET PLUS PREMIUM IRON REAR HUBS
Rear Disc Wheels (505)	ALCOA 77362X 19.5X7.50 10-HUB PILOT ALUMINUM DISC REAR WHEELS
Rear Tires (094)	MICHELIN XZE 245/70R19.5 16 PLY RADIAL REAR TIRES
Rear Brakes (423)	MERITOR 15X8.62 Q+ CAST SPIDER CAM REAR BRAKES, DOUBLE ANCHOR, FABRICATED SHOES
Pusher / Tag Axle (443)	NO PUSHER OR TAG AXLE
Pusher / Tag Suspension (626)	NO PUSHER OR TAG SUSPENSION
Pusher / Tag Hubs (449)	NO PUSHER OR TAG HUBS
Pusher/Tag Disc Wheels (509)	NO PUSHER/TAG DISC WHEELS
Pusher / Tag Tires (095)	NO PUSHER/TAG TIRES
Pusher / Tag Brakes (456)	NO PUSHER/TAG BRAKES

TABLE SUMMARY - GVWR



Prepared for:
 Mike Harper
 REV GROUP_HORTON
 EMERGENCY VEHICLES
 3800 McDowell Rd
 Grove City, OH 43123
 Phone: 614-539-8181 Ex 316

Prepared by:
 Mark Mims
 PREMIER TRUCK GROUP OF
 DALLAS
 4200 PORT BOULEVARD
 DALLAS, TX 75241
 Phone: 972-225-4360

	Front	Rear
Axle Component Weight Ratings		
Axes	8000	17500
Suspension	8000	12000
Hubs	14700	26000
Brakes	9999	20000
Wheels	13400	26800
Tires	9880	18700
Power Steering	13300	N/A
GAWR (per axle)	8000	12000
GAWR (per axle system)	8000	12000
Expected Load (per axle system)	8000	12000
GVWR due to Frame	35000	
Vehicle GVWR Summary		
Calculated GVWR	20000	
Expected GVWR	20000	
All weights displayed in pounds		

Performance calculations are estimates only. If performance calculations are critical, please contact Customer Application Engineering.



Prepared for:
 Mike Harper
 REV GROUP_HORTON
 EMERGENCY VEHICLES
 3800 McDowell Rd
 Grove City, OH 43123
 Phone: 614-539-8181 Ex 316

Prepared by:
 Mark Mims
 PREMIER TRUCK GROUP OF
 DALLAS
 4200 PORT BOULEVARD
 DALLAS, TX 75241
 Phone: 972-225-4360

UNLADEN FRAME HEIGHT

Unladen Height	Requested	Calculated
Frame (in)	N/A	33.10

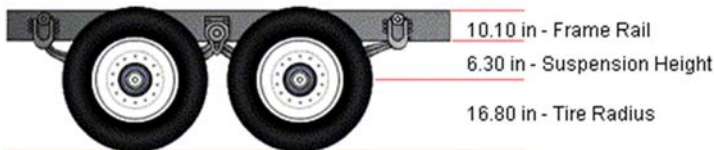

VEHICLE SPECIFICATIONS SUMMARY - UNLADEN FRAME HEIGHT

Model M2106
 Cab Size (829) 106 INCH BBC FLAT ROOF ALUMINUM CONVENTIONAL CAB
 Frame Rails (546) 9/32X3-7/16X10-1/16 INCH STEEL FRAME (7.14MMX255.6/0.281X10.06 INCH) 80KSI (546)
 Web Height (in) 10.0625
 Flange Thickness (in) 0.28125
 Rear Suspension (622) AIRLINER 12,000# REAR SUSPENSION
 Rear Suspension Ride Height (621) AIRLINER MID POSITION RIDE HEIGHT
 Axle C/L to Bottom of Frame (in) 6.279
 Rear Tires (094) MICHELIN XZE 245/70R19.5 16 PLY RADIAL REAR TIRES
 Unladen Radius (in) 16.8
 Fifth Wheel (578) NO FIFTH WHEEL
 Requested Min Height (in) 0.0
 Requested Max Height (in) 1
 Fifth Wheel Leg Height (582) NO FIFTH WHEEL LEG HEIGHT
 Rear Tow Device (587) NO REAR TOWING DEVICE
 Requested Min Height (in) 0.0
 Requested Max Height (in) 0.0

Performance calculations are estimates only. If performance calculations are critical, please contact Customer Application Engineering.



Prepared for:
 Mike Harper
 REV GROUP_HORTON
 EMERGENCY VEHICLES
 3800 McDowell Rd
 Grove City, OH 43123
 Phone: 614-539-8181 Ex 316

Prepared by:
 Mark Mims
 PREMIER TRUCK GROUP OF
 DALLAS
 4200 PORT BOULEVARD
 DALLAS, TX 75241
 Phone: 972-225-4360

TURNING RADIUS



Turning radius graphic and data provided for general estimate purposes only. For specific figures regarding your configuration, please contact your CAE representative.

	Left Turn	Right Turn	Tolerance
Wall to Wall Diameter (ft)	44.0	35.9	+/- 3.0
Curb to Curb Diameter (ft)	42.2	33.8	+/- 3.0
Turning Radius (ft)	20.7	16.5	+/- 1.5

VEHICLE SPECIFICATIONS SUMMARY - TURNING RADIUS

Model M2106
 Cab Size (829) 106 INCH BBC FLAT ROOF ALUMINUM CONVENTIONAL CAB
 Wheelbase (545) 3875MM (153 INCH) WHEELBASE
 Front Tires (093) MICHELIN XZE 245/70R19.5 16 PLY RADIAL FRONT TIRES
 Width (in) 9.7
 Front Axle (400) DETROIT DA-F-8.0-3 8,000# FF1 71.5 KPI/3.74 DROP SINGLE FRONT AXLE
 Kingpin Intersection (in) 71.5
 Bumper (556) THREE-PIECE 14 INCHES CHROMED STEEL BUMPER WITH COLLAPSIBLE ENDS
 Width (in) 93.5
 Bumper Miter to Front Axle (in) 21.458
 Primary Steering Location (003) LH PRIMARY STEERING LOCATION
 Steering Gear (536) TRW THP-60 POWER STEERING
 Dual Steering Gear NONE
 Ram NONE
 Rear Axle (420) DETROIT DA-RS-17.5-2 17,500# R-SERIES SINGLE REAR AXLE
 Axle Spacing (624) NO AXLE SPACING

Performance calculations are estimates only. If performance calculations are critical, please contact Customer Application Engineering.





City of Larkspur, CA

Balance Sheet

Account Summary

As Of 06/30/2018

Account	Name	Prior Year Balance	Current Year Balance	Variance Favorable / (Unfavorable)
Fund: 705 - ROSS VALLEY PARAMEDIC				
Assets				
705-0000-100001	POOLED CASH	1,547,135.52	765,221.38	-781,914.14
705-0000-100003	WESTAMERICA BANK	0.00	0.00	0.00
705-0000-150000	ACCOUNTS RECEIVABLE	41,743.67	61,916.55	20,172.88
705-0000-150001	ACCOUNTS RECEIVABLE/GOVT	0.00	0.00	0.00
705-0000-150002	ACCOUNTS RECEIVABLE/INTEREST	0.00	0.00	0.00
705-0000-160000	PREPAID EXPENSES	-0.12	-0.12	0.00
	Total Assets:	<u>1,588,879.07</u>	<u>827,137.81</u>	<u>-761,741.26</u>
Liability				
705-0000-200001	ACCOUNTS PAYABLE	788,635.93	19,588.26	769,047.67
705-0000-625014	MISC DEPOSITS	7,135.00	12,225.40	-5,090.40
	Total Liability:	<u>795,770.93</u>	<u>31,813.66</u>	<u>763,957.27</u>
Equity				
705-0000-900000	FUND BALANCE	430,521.13	693,108.14	262,587.01
705-0000-900001	FUND BALANCE RESERVE	100,000.00	100,000.00	0.00
705-0000-900002	FUND BALANCE- RESERVE EQUIPMENT	130,350.00	0.00	-130,350.00
705-9996-000000	APPROPRIATIONS	0.00	0.00	0.00
705-9997-000001	ESTIMATED REVENUE	0.00	0.00	0.00
	Total Beginning Equity:	<u>660,871.13</u>	<u>793,108.14</u>	<u>132,237.01</u>
Total Revenue		2,275,486.31	2,364,509.39	89,023.08
Total Expense		2,143,249.30	2,362,293.38	-219,044.08
Revenues Over/(Under) Expenses		<u>132,237.01</u>	<u>2,216.01</u>	<u>-130,021.00</u>
	Total Equity and Current Surplus (Deficit):	<u>793,108.14</u>	<u>795,324.15</u>	<u>2,216.01</u>
	Total Liabilities, Equity and Current Surplus (Deficit):	<u>1,588,879.07</u>	<u>827,137.81</u>	<u>-761,741.26</u>



City of Larkspur, CA

Budget Report

Account Summary

For Fiscal: 2017-2018 Period Ending: 06/30/2018

		Original Total Budget	Current Total Budget	Period Activity	Fiscal Activity	Variance Favorable (Unfavorable)	Percent Remaining
Fund: 705 - ROSS VALLEY PARAMEDIC							
Revenue							
705-1204-101004	INVESTMENT EARNINGS	0.00	2,200.00	0.00	5,596.79	3,396.79	254.40 %
705-1205-200002	KENTFIELD FIRE DIST	196,143.00	196,143.00	9,731.70	194,634.00	-1,509.00	0.77 %
705-1205-200003	CITY OF LARKSPUR	526,000.00	526,000.00	26,119.40	526,509.29	509.29	100.10 %
705-1205-200004	COUNTY SER AREA 27	50,750.00	50,750.00	2,578.20	51,564.00	814.00	101.60 %
705-1205-200007	TOWN OF FAIRFAX	-260,036.00	260,036.00	12,908.75	258,175.00	-1,861.00	0.72 %
705-1205-200009	TOWN OF ROSS	66,535.00	66,535.00	3,319.20	66,384.00	-151.00	0.23 %
705-1205-200010	SLEEPY HOLLOW FIRE DIST	63,250.00	63,250.00	3,170.20	63,404.00	154.00	100.24 %
705-1205-200013	SAN ANSELMO	414,000.00	414,000.00	20,370.35	408,727.50	-5,272.50	1.27 %
705-1207-103000	OTHER REVENUE	0.00	0.00	0.00	37,279.52	37,279.52	0.00 %
705-1207-103005	TRANSPORT BILLING	796,000.00	796,000.00	88,014.55	752,235.29	-43,764.71	5.50 %
	Revenue Total:	1,852,642.00	2,374,914.00	166,212.35	2,364,509.39	-10,404.61	0.44 %
Expense							
705-0046-000-003000	PART TIME	7,000.00	7,000.00	720.00	3,040.00	3,960.00	56.57 %
705-0046-001-012001	FINANCIAL & ADMINISTRATIVE SERVI...	47,326.00	47,326.00	0.00	28,143.00	19,183.00	40.53 %
705-0046-001-012003	ALS BACK UP	0.00	62,500.00	9,423.77	41,521.40	20,978.60	33.57 %
705-0046-001-012012	CONSULTANT	0.00	5,000.00	0.00	1,519.00	3,481.00	69.62 %
705-0046-001-012038	TRANSPORT BILLING FEES	0.00	40,000.00	0.00	18,885.74	21,114.26	52.79 %
705-0046-001-012039	PARCEL TAX TRANSFER TO CM	0.00	8,000.00	8,037.00	8,037.00	-37.00	-0.46 %
705-0046-001-016000	LEGAL SERVICES	0.00	12,000.00	3,386.25	3,386.25	8,613.75	71.78 %
705-0046-001-018000	COUNTY CONTRACT	0.00	1,477,204.00	0.00	1,473,083.04	4,120.96	0.28 %
705-0046-002-021000	AUTOMOTIVE FUELS	0.00	10,000.00	0.00	3,889.35	6,110.65	61.11 %
705-0046-002-024000	PRINTED & PHOTOGRAPHIC	0.00	1,000.00	0.00	225.00	775.00	77.50 %
705-0046-002-026000	OFFICE SUPPLIES	0.00	200.00	0.00	0.00	200.00	100.00 %
705-0046-002-028002	ENGINE MEDIC PROGRAM - RVFD	0.00	199,000.00	0.00	209,398.46	-10,398.46	-5.23 %
705-0046-002-028003	ENGINE MEDIC PROGRAM - LARKSPUR	0.00	120,000.00	0.00	90,000.00	30,000.00	25.00 %
705-0046-002-028004	EMS TRAINING/SUPPLY REIMB	0.00	90,000.00	0.00	90,000.00	0.00	0.00 %
705-0046-002-028010	DISPOSABLE MEDICAL SUPPLIES	0.00	75,000.00	6,632.98	70,726.21	4,273.79	5.70 %
705-0046-004-040000	POSTAGE	0.00	800.00	145.26	688.68	111.32	13.92 %
705-0046-004-090002	MISC	0.00	1,000.00	0.00	0.00	1,000.00	100.00 %
705-0046-005-053000	AUTOMOTIVE EQUIPMENT REPAIRS	0.00	4,500.00	1,138.96	15,280.12	-10,780.12	-239.56 %
705-0046-006-064000	INSURANCE/MISC	0.00	8,000.00	0.00	4,702.00	3,298.00	41.23 %
705-0046-007-073008	TAX COLLECTION SERVICE	0.00	8,000.00	0.00	7,917.50	82.50	1.03 %
705-0046-007-074000	RENT	28,834.95	28,834.95	0.00	28,834.95	0.00	0.00 %
705-0046-008-087001	OTHER EQUIPMENT/BUILDING	0.00	2,000.00	77.45	896.40	1,103.60	55.18 %
705-0046-008-087002	EQUIPMENT REPLACEMENT	0.00	258,144.41	0.00	262,119.28	-3,974.87	-1.54 %
	Expense Total:	83,160.95	2,465,509.36	29,561.67	2,362,293.38	103,215.98	4.19 %
	Fund: 705 - ROSS VALLEY PARAMEDIC Surplus (Deficit):	1,769,481.05	-90,595.36	136,650.68	2,216.01	92,811.37	102.45 %
	Report Surplus (Deficit):	1,769,481.05	-90,595.36	136,650.68	2,216.01	92,811.37	102.45 %

Group Summary

Account Typ...	Original Total Budget	Current Total Budget	Period Activity	Fiscal Activity	Variance Favorable (Unfavorable)	Percent Remaining
Fund: 705 - ROSS VALLEY PARAMEDIC						
Revenue	1,852,642.00	2,374,914.00	166,212.35	2,364,509.39	-10,404.61	0.44 %
Expense	83,160.95	2,465,509.36	29,561.67	2,362,293.38	103,215.98	4.19 %
Fund: 705 - ROSS VALLEY PARAMEDIC Surplus (Deficit):	1,769,481.05	-90,595.36	136,650.68	2,216.01	92,811.37	102.45 %
Report Surplus (Deficit):	1,769,481.05	-90,595.36	136,650.68	2,216.01	92,811.37	102.45 %

Fund Summary

Fund	Original Total Budget	Current Total Budget	Period Activity	Fiscal Activity	Variance Favorable (Unfavorable)
705 - ROSS VALLEY PARAMEDIC	1,769,481.05	-90,595.36	136,650.68	2,216.01	92,811.37
Report Surplus (Deficit):	1,769,481.05	-90,595.36	136,650.68	2,216.01	92,811.37



City of Larkspur, CA



Account Detail

ate range: 06/01/2018 - 06/30/2018

Account	Name	Beginning Balance	Total Activity	Ending Balance				
Fund: 705 - ROSS VALLEY PARAMEDIC								
705-0046-000-003000	PART TIME	2,320.00	720.00	3,040.00				
Post Date	Packet Number	Source Transaction	Pmt Number	Description	Vendor	Project Account	Amount	Running Balance
06/14/2018	APPKT04098	05/30/2018	73733	RVPA - Board Stipend 05/30/2018	1465 - Corbet, Bruce		100.00	2,420.00
06/14/2018	APPKT04098	05/30/2018	73741	RVPA - Board Stipend 05/30/2018	1590 - Hillmer, Dan		100.00	2,520.00
06/14/2018	APPKT04098	05/30/2018	73740	RVPA - Board Stipend 05/30/2018	1072 - Finn, Thomas J.		100.00	2,620.00
06/14/2018	APPKT04098	05/30/2018	73751	RVPA - Board Stipend 05/30/2018	1688 - Przybylski, Janice		100.00	2,720.00
06/14/2018	APPKT04098	05/30/2018	73753	RVPA - Board Stipend 05/30/2018	2758 - Reed, John		100.00	2,820.00
06/19/2018	APPKT04105	RVPA 05/30/2018	73766	RVPA - Board Stipend 05/30/2018	5553 - Bailey, Sloan		100.00	2,920.00
06/19/2018	APPKT04105	RVPA 05/30/2018	73775	RVPA - Board Meeting Minutes 05/30/	1236 - DeFrancis, Toni		120.00	3,040.00
705-0046-001-012039	PARCEL TAX TRANSFER TO CM	0.00	8,037.00	8,037.00				
Post Date	Packet Number	Source Transaction	Pmt Number	Description	Vendor	Project Account	Amount	Running Balance
06/14/2018	APPKT04098	FIN-0001	73734	RVPA - 2018 CSA Payment	1382 - CORTE MADERA /TOWN OF		8,037.00	8,037.00
705-0046-005-053000	AUTOMOTIVE EQUIPMENT REPAIRS	14,141.16	1,138.96	15,280.12				
Post Date	Packet Number	Source Transaction	Pmt Number	Description	Vendor	Project Account	Amount	Running Balance
06/14/2018	APPKT04098	004693	73744	RVPA - LIC 1438762 13 Ford F550 Repa	5531 - Marin County / County of Marin De		1,138.96	15,280.12
705-0046-008-087001	OTHER EQUIPMENT/BUILDING	818.95	77.45	896.40				
Post Date	Packet Number	Source Transaction	Pmt Number	Description	Vendor	Project Account	Amount	Running Balance
06/14/2018	APPKT04098	8155 30 0005735 05/	73732	RVPA - Internet Services JUN 2018	4741 - Comcast - RVPA / Rescue 40		77.45	896.40
Total Fund: 705 - ROSS VALLEY PARAMEDIC:		Beginning Balance:	17,280.11	Total Activity:	9,973.41	Ending Balance:	27,253.52	
Grand Totals:		Beginning Balance:	17,280.11	Total Activity:	9,973.41	Ending Balance:	27,253.52	

Fund Summary

Fund	Beginning Balance	Total Activity	Ending Balance
705 - ROSS VALLEY PARAMEDIC	17,280.11	9,973.41	27,253.52
Grand Total:	17,280.11	9,973.41	27,253.52

RVPA APRIL 2018 DEPOSITS

<u>DATE</u>	<u>AMOUNT</u>	<u>DESCRIPTION</u>		
4/2/2018	\$ 6,257.48	\$3,074.91 & \$354.13 MEDICARE EFT		
4/3/2018	\$ -	NO DEPOSIT		
4/4/2018	\$ -	NO DEPOSIT		
4/5/2018	\$ -	NO DEPOSIT		
4/6/2018	\$ 2,745.60			
4/9/2018	\$ 9,100.15	\$3,085.04 MEDICARE EFT		
4/10/2018	\$ 8,875.87			
4/11/2018	\$ -	NO DEPOSIT		
4/12/2018	\$ 131.40	\$24.77 MEDICARE EFT		
4/13/2018	\$ 2,583.14			
4/16/2018	\$ 5,849.20	\$3,372.10, \$412.11 & \$3.65 MEDICARE EFT'S		
4/17/2018	\$ 345.77			
4/18/2018	\$ -	NO DEPOSIT		
4/19/2018	\$ 1,950.67			
4/20/2018	\$ 108.77			
4/23/2018	\$ 2,161.79			
4/24/2018	\$ 1,283.39			
4/25/2018	\$ 463.10			
4/26/2018	\$ 200.00			
4/27/2018	\$ 6,417.60	\$3,624.01 MEDICARE EFT		
4/30/2018	\$ 4,328.16			
TOTAL	<u>\$ 52,802.09</u>			
REFUNDS	\$ -			
REFUNDS	\$ -			
REFUNDS	\$ -			
TOTAL	<u>\$ 52,802.09</u>			
<u>TOTAL CALLS</u>	<u>NON-BILLABLE CALLS</u>	<u>BILLABLE CALLS</u>	<u>RATE</u>	<u>AMOUNT DUE</u>
202	72	130	\$18.00	<u>\$2,340.00</u>

BALANCED AND COMPLETE